



UNIVERSITAT POLITÈCNICA
DE CATALUNYA
BARCELONATECH

*Decision support strategies
for the efficient
implementation of circular
economy principles in
process systems*

Ana Somoza Tornos

ADVERTIMENT La consulta d'aquesta tesi queda condicionada a l'acceptació de les següents condicions d'ús: La difusió d'aquesta tesi per mitjà del repositori institucional UPCommons (<http://upcommons.upc.edu/tesis>) i el repositori cooperatiu TDX (<http://www.tdx.cat/>) ha estat autoritzada pels titulars dels drets de propietat intel·lectual **únicament per a usos privats** emmarcats en activitats d'investigació i docència. No s'autoritza la seva reproducció amb finalitats de lucre ni la seva difusió i posada a disposició des d'un lloc aliè al servei UPCommons o TDX. No s'autoritza la presentació del seu contingut en una finestra o marc aliè a UPCommons (*framing*). Aquesta reserva de drets afecta tant al resum de presentació de la tesi com als seus continguts. En la utilització o cita de parts de la tesi és obligat indicar el nom de la persona autora.

ADVERTENCIA La consulta de esta tesis queda condicionada a la aceptación de las siguientes condiciones de uso: La difusión de esta tesis por medio del repositorio institucional UPCommons (<http://upcommons.upc.edu/tesis>) y el repositorio cooperativo TDR (<http://www.tdx.cat/?locale-attribute=es>) ha sido autorizada por los titulares de los derechos de propiedad intelectual **únicamente para usos privados enmarcados** en actividades de investigación y docencia. No se autoriza su reproducción con finalidades de lucro ni su difusión y puesta a disposición desde un sitio ajeno al servicio UPCommons No se autoriza la presentación de su contenido en una ventana o marco ajeno a UPCommons (*framing*). Esta reserva de derechos afecta tanto al resumen de presentación de la tesis como a sus contenidos. En la utilización o cita de partes de la tesis es obligado indicar el nombre de la persona autora.

WARNING On having consulted this thesis you're accepting the following use conditions: Spreading this thesis by the institutional repository UPCommons (<http://upcommons.upc.edu/tesis>) and the cooperative repository TDX (<http://www.tdx.cat/?locale-attribute=en>) has been authorized by the titular of the intellectual property rights **only for private uses** placed in investigation and teaching activities. Reproduction with lucrative aims is not authorized neither its spreading nor availability from a site foreign to the UPCommons service. Introducing its content in a window or frame foreign to the UPCommons service is not authorized (*framing*). These rights affect to the presentation summary of the thesis as well as to its contents. In the using or citation of parts of the thesis it's obliged to indicate the name of the author.

Decision Support Strategies for the Efficient Implementation of Circular Economy Principles in Process Systems

This dissertation is submitted for the degree
of Doctor of Philosophy by

Ana Somoza Tornos

Advised by

Prof. Antonio Espuña Camarasa

Prof. Moisès Graells Sobré



Universitat Politècnica de Catalunya
PhD Program in Chemical Process Engineering

March 2020

Copyright © 2020 by Ana Somoza Tornos

The copyright of this Thesis rests with the author. No quotations of it should be published without the author's prior writer consent and information derived from it should be acknowledged.

Trademark names are used in this book without the inclusion of the trademark symbol. These names are used in an editorial context only; no infringement of trademark is intended. All the trademarked names cited in this Thesis are © of their respective owners.

A mis padres.

*None but those who have experienced them
can conceive of the enticements of science.*

Mary Shelley

Frankenstein; or, the modern Prometheus (1818)

Summary

Economic growth at any expense is no longer an option. Awareness of the growing human footprint is crucial to face the problems that the impoverishment of ecosystems is causing and will cause in the future. One of the key challenges to address it is moving toward approaches to manage resources in a more sustainable way. In this light, circular economy stands as a promising strategy to improve the lifetime of resources by closing material and energy loops.

The Process Systems Engineering (PSE) community has been developing methods and tools for increasing efficiency in process systems since the late 1980s. These methods and tools allow the development of more sustainable products, processes, and supply chains. However, applying these tools to circular economy requires special considerations when evaluating the introduction of waste-to-resource technologies. This Thesis aims at providing a set of models and tools to support in the decision-making process of closing material cycles in process systems through the implementation of waste-to-resource technologies from the circular economy perspective.

The first part provides an overview of approaches to sustainability, presents the optimization challenges that circular economy and industrial symbiosis pose to PSE, and introduces the methodological and industrial scope of the Thesis. Part two aims at assessing the environmental and economic reward that may be attained through the application of circular economy principles in the chemical industry. With this purpose, a systematic procedure based on Life Cycle Assessment (LCA), economic performance and Technology Readiness Level (TRL) is proposed to characterize technologies and facilitate the comparison of traditional and novel technologies.

The third part describes groundwork tasks for optimization models. A methodology is presented for the systematic generation of a list of potential

waste-to-resource technologies based on an ontological framework to structure the information. In addition, this part also presents a targeting approach developed to include waste transformation and resource outsourcing, so a new dimension of potential destinations for waste are explored for the extension of material recovery.

Finally, part four includes the development of decision-making models at the strategic and tactical hierarchical levels. At the network level, a framework is presented for the screening of waste-to-resource technologies in the design of process networks. The most promising processing network for waste recovery is identified by selecting the most favorable waste transformation processes among a list of potential alternatives. After the network selection, an optimization model is built for the detailed synthesis of individual processes selected in the resulting network.

The developed methodologies have been validated and illustrated through their application to a case study under different viewpoints in the process industry, in particular to the chemical recycling of plastic waste. Despite the low Technology Readiness Level of some chemical recycling technologies, the results of this Thesis reveal pyrolysis as a promising technology to close the loop in the polymer sector.

Overall, all these positive outcomes prove the advantages of developing tools to systematically integrate waste-to-resource processes into the life cycle of materials. The adaptation to this change of perspective of the well-established methods developed by the PSE community offers a wide range of opportunities to foster circular economy and industrial symbiosis. This Thesis aims to be a step forward towards a future with more economically efficient and environmentally friendly life cycles of materials.

Resumen

El crecimiento económico a cualquier precio ha dejado de ser una opción viable. Tener conciencia sobre nuestra creciente huella ambiental es clave para afrontar los problemas que el empobrecimiento de los ecosistemas está causando y causará en el futuro. Uno de los desafíos clave para abordarlo es avanzar hacia técnicas que permitan una gestión de recursos más sostenible. En esta línea, la economía circular es una estrategia con gran potencial para mejorar la vida útil de los recursos mediante el cierre de ciclos de materiales y energía.

Desde finales de los años ochenta, la investigación en Ingeniería de Procesos y Sistemas (PSE) ha permitido generar métodos y herramientas para el desarrollo sostenible de productos, procesos y cadenas de suministro. Sin embargo, su aplicación en economía circular requiere consideraciones especiales al evaluar la introducción de nuevas tecnologías para el reciclaje de materiales. Esta Tesis tiene como objetivo proporcionar un conjunto de modelos y herramientas para apoyar el proceso de toma de decisiones sobre el aprovechamiento de materiales a través de la lente de la economía circular mediante la implementación de tecnologías de conversión de residuos en recursos.

La primera parte presenta una visión general de los enfoques de sostenibilidad, lista los desafíos que la economía circular y la simbiosis industrial plantean en PSE, e introduce el alcance metodológico e industrial de la Tesis. La segunda parte tiene como objetivo evaluar los beneficios ambientales y económicos que se pueden obtener mediante la aplicación de los principios de la economía circular en la industria química. Con este propósito, se desarrolla un método sistemático basado en el análisis del ciclo de vida, el rendimiento económico y el nivel de madurez tecnológica para caracterizar las tecnologías de recuperación y facilitar la comparación entre técnicas tradicionales y en desarrollo.

La tercera parte describe las tareas previas al desarrollo de los modelos de optimización. Se presenta una metodología para la generación sistemática de una lista de posibles tecnologías de conversión de residuos en recursos utilizando en un marco ontológico para estructurar la información. Además, se expone un método para acotar la transformación de residuos y la externalización de recursos, que permite explorar una nueva dimensión de destinos potenciales para los residuos, extendiendo así el grado de recuperación de materiales.

Por último, la cuarta parte incluye el desarrollo de modelos de toma de decisiones a nivel estratégico y táctico. A nivel estratégico, se presenta un marco para la detección de tecnologías de reciclaje de residuos en el diseño de redes de procesos. Tras sintetizar la red, a nivel táctico se construye un modelo de optimización para el diseño detallado de los procesos individuales seleccionados en el mismo.

Las metodologías desarrolladas han sido ilustradas y validadas a través de su aplicación en un caso de estudio con diferentes perspectivas sobre el reciclaje químico de residuos plásticos. A pesar del bajo nivel de madurez tecnológica de los procesos de reciclaje químico, los resultados de esta Tesis permiten identificar el gran potencial económico y ambiental de la pirolisis de residuos plásticos para cerrar su ciclo de materiales.

En conjunto, los resultados demuestran las ventajas de desarrollar herramientas para integrar sistemáticamente los procesos de reciclaje de residuos en el ciclo de vida de los materiales. La adaptación a las necesidades de este cambio de perspectiva de métodos bien establecidos en la comunidad PSE ofrece grandes oportunidades para fomentar la economía circular y la simbiosis industrial. Esta tesis pretende ser un paso adelante hacia un futuro con ciclos de vida de materiales económica y ambientalmente más eficientes.

Acknowledgements

My eternal gratitude to my supervisors, Prof. Antonio Espuña and Prof. Moisès Graells, for their support and dedication during all these years. Thanks for giving me invaluable guiding and advice but also the freedom to explore new concepts.

I would also like to thank Prof. Luis Puigjaner for patiently supervising some of the contributions resulting from this Thesis and Prof. Montserrat Pérez-Moya for sharing her knowledge on innovative teaching with me. I extend my appreciation to the former and current members of CEPIMA: Canan Dombayci, Gicela Lupera, Sergio Medina, Shabnam Morakabatchiankar, Kourosch Nasr, Adrián Pacheco and Xiangwei Yu. My special gratitude to Francesca Audino and Patricia Vicente, for our innumerable adventures on campus.

I am deeply grateful to Prof. Gonzalo Guillén and the Centre for Process Systems Engineering at Imperial College London for welcoming me for a very productive research stay. I extend my gratitude to the group members with whom I shared this wonderful experience: Ibrahim Algunaibet, Raúl Calvo, Lucian Gomoescu, Phantisa Limleamthong, Daniel Rodríguez, Ariel Uribe and Yukun Wang. I thank Amjad Al-Qahtani and David Lorenzo for the good moments we shared and Andrés González for helping me with AspenPlus and SimaPro. My deepest thanks to Dr. Carlos Pozo, for being an unending source of optimization and life advice.

My greatest gratitude to Prof. Ignacio Grossmann for giving me the opportunity to do a fruitful research stay at the Center for Advanced Process Decision-Making at Carnegie Mellon University. I would also like to thank all the new friends that I made there for making me feel at home even though I was so far from my hometown: David Bernal, Sara Caldas, Qi Chen, Eike Cramer, Chris Hanselman, Cristiana Lara, Can Li, Kai Liu, Cornelius

Masuku, Carlos Nohra, Maria Paz Ochoa, Héctor Pérez, Christina Schenk, Michael Short, David Thierry and Yixin Ye.

Thanks to all my friends who have accompanied me throughout this journey. Carlos, Francesca, Mireia, Patricia and Verónica, thanks for always being there.

Finally, I am truly indebted to my parents for their unlimited support, understanding and unconditional love. I really thank you for encouraging me through the best and worst of this journey. Thanks are also due to the other members of my family for believing in me.

Agradecimientos

Mi más sincero agradecimiento a mis directores de tesis, los Prof. Antonio España y Prof. Moisès Graells, por su apoyo y dedicación durante todos estos años. Gracias por vuestros consejos y supervisión, pero también por darme la libertad para explorar nuevas ideas.

Me gustaría agradecer también al Prof. Luis Puigjaner por su inestimable colaboración en contribuciones derivadas de esta tesis y a la Prof. Montserrat Pérez-Moya por compartir su conocimiento sobre innovación docente conmigo. Gracias también a los otros miembros de CEPIMA: Canan Dombayci, Gicela Lupera, Sergio Medina, Shabnam Morakabatchiankar, Kourosh Nasr, Adrián Pacheco y Xiangwei Yu. Mi especial agradecimiento a Francesca Audino y Patricia Vicente, sin vosotras y nuestras aventuras esta experiencia no hubiera sido lo mismo.

Estoy muy agradecida al Prof. Gonzalo Guillén y el Center for Process Systems Engineering de Imperial College London por darme la bienvenida para una provechosa estancia de investigación. Gracias a los miembros del grupo que compartieron conmigo esta experiencia maravillosa: Ibrahim Algunaibet, Raúl Calvo, Lucian Gomoescu, Phantisa Limleamthong, Daniel Rodríguez, Ariel Uribe y Yukun Wang. Agradezco a Amjad Al-Qahtani y David Lorenzo por los buenos momentos que compartimos y a Andrés González por ayudarme con AspenPlus y SimaPro. Mi más sincero agradecimiento al Dr. Carlos Pozo, por ser una fuente inagotable de consejos y conocimientos sobre optimización.

Mi más profundo agradecimiento al Prof. Ignacio Grossmann por darme la oportunidad de hacer una estancia de investigación en el Center for Advanced Process Decision-Making en Carnegie Mellon University. Me gustaría también dar las gracias a los amigos que hice allí, por hacerme sentir como en casa tan lejos de mi ciudad: David Bernal, Sara Caldas, Qi Chen, Eike Cramer, Chris Hanselman, Cristiana Lara, Can Li, Kai Liu, Cornelius

Masuku, Carlos Nohra, Maria Paz Ochoa, Héctor Pérez, Christina Schenk, Michael Short, David Thierry y Yixin Ye.

Gracias a todos los amigos que me han acompañado en este viaje. Carlos, Francesca, Mireia, Patricia y Verónica, mil gracias por estar siempre ahí.

Por último, estoy eternamente agradecida a mis padres por su apoyo, comprensión y amor incondicional. Os doy las gracias por estar conmigo en los buenos y malos momentos de esta experiencia. Gracias también a los otros miembros de mi familia por creer en mí.

Contents

Part I. Overview.....	1
1 Introduction	3
1.1. Perspective and motivation	3
1.2. Approaches to sustainable development	5
1.2.1. Circular economy	5
1.2.2. Industrial ecology	7
1.2.3. Industrial symbiosis	8
1.3. Research scope and objectives	9
1.4. Thesis outline	11
2 State of the art	13
2.1. Sustainability in Process Systems Engineering (PSE).....	13
2.2. Literature review	15
2.2.1. Keywords and trends	15
2.2.2. Performance assessment and objective function	18
2.2.3. Data management.....	20
2.2.4. Challenges	20
2.3. Trends and challenges	21
3 Methods and tools.....	23
3.1. Introduction	23

3.2.	Modeling and simulation	24
3.2.1.	Sequential-modular	24
3.2.2.	Equation-oriented	24
3.3.	Mathematical programming	25
3.3.1.	General disjunctive programming	26
3.3.2.	Multi-objective optimization	26
3.3.3.	Uncertainty management	28
3.3.4.	Software	30
3.4.	Life cycle assessment.....	31
3.4.1.	Software, databases and solution methods	31
4	Optimization framework	33
4.1.	General problem statement.....	33
4.2.	Framework for the synthesis of material exchange networks 34	
4.3.	Industrial scope.....	36
4.3.1.	The problem of plastic waste	36
4.3.2.	End-of-life alternatives for plastic waste	37

Part II: Study of the potential benefits of circular economy in the chemical industry39

5	Methodology for the characterization of waste-to-resource technologies	41
5.1.	Introduction.....	41
5.2.	Parameter estimation	41
5.3.	Simulation.....	42
5.4.	Economic assessment.....	43
5.5.	Life cycle assessment.....	44
5.6.	Technology readiness levels.....	45

5.7.	Echelons and supply chain assessment.....	46
6	Application on individual echelons	49
6.1.	Introduction	49
6.2.	Materials and methods	51
6.3.	Parameter estimation and simulation.....	51
6.4.	Economic assessment.....	54
6.5.	Environmental assessment.....	55
6.6.	Results.....	59
6.6.1.	Economic assessment	59
6.6.2.	Environmental assessment.....	65
6.7.	Remarks	71
7	Application on the entire supply chain.....	73
7.1.	Introduction	73
7.2.	System description	73
7.3.	Materials and methods	75
7.4.	Economic assessment.....	78
7.5.	Environmental assessment.....	81
7.6.	Results.....	84
7.6.1.	Economic assessment	84
7.6.2.	Environmental assessment.....	86
7.7.	Remarks	88

Part III: Preliminary steps **89**

8	Generation of waste-to-resource routes.....	91
8.1.	Introduction	91
8.2.	Problem statement.....	92
8.3.	Methodology	92

8.3.1.	Ontological framework	93
8.3.2.	Sorting and classification of instances (reasoner).....	93
8.4.	Case study	95
8.5.	Results	96
8.6.	Remarks	98
9	Targeting material exchanges.....	99
9.1.	Introduction.....	99
9.2.	Chemical targeting	99
9.3.	Extended targeting	100
9.3.1.	Problem statement	101
9.3.2.	Mathematical formulation.....	102
9.3.3.	Case study	103
9.3.4.	Results	104
9.3.5.	Remarks.....	106

Part IV: Decision-making tools for the implementation of circular economy principles in process systems.....107

10	Synthesis of circular economy networks	109
10.1.	Introduction.....	109
10.2.	Problem statement.....	111
10.3.	Mathematical formulation.....	112
10.3.1.	Stochastic model	114
10.4.	Solution procedure.....	115
10.5.	Case study	116
10.6.	Results	124
10.7.	Remarks	130

11	Synthesis of flexible processes with material recovery opportunities.....	133
11.1.	Introduction	133
11.2.	Problem statement.....	134
11.3.	Joint process and product synthesis	134
11.3.1.	Superstructure representation	134
11.3.2.	GDP formulation	135
11.3.3.	Model resolution.....	136
11.4.	Case study	137
11.5.	Results.....	137
11.5.1.	Superstructure representation	137
11.5.2.	Model formulation	138
11.5.3.	Model resolution.....	140
11.6.	Remarks	141
<hr/> Part V: Conclusions and outlook		143
12	Conclusions and future work.....	145
12.1.	Main contributions.....	145
12.2.	Future work.....	147
	References	149

Part I. Overview

Chapter 1

Introduction

1.1. Perspective and motivation

Economic growth at any expense is no longer an option. According to some authors, after the exponential growth of the last centuries we might have exceeded the capacity of natural resources (Jackson, 2009; Meadows et al., 2005). Deforestation, fossil fuels shortage, biodiversity loss and water, air and soil pollution are some of the effects of human activity. But resources are finite and its scarcity and degradation will probably lead to devastating consequences in coming years.

Demographic growth projections estimate that population could reach 10 billion by 2050, and this increase is mainly attributed to a few developing countries (Melorose et al., 2015). This will lead to a rise in the demand of natural resources, increasing the pressure on ecosystems that are already overexploited.

Awareness of this growing human footprint is crucial to face the problems that the impoverishment of ecosystems is causing and will cause in the future. Actions against climate change have been controversial worldwide during the past years but, based on current conditions and future predictions, scientists have recently raised the need to classify the situation as climate emergency (Ripple et al., 2019). Some governments have declared climate emergency and started corrective actions to mitigate it. For instance, Europe acknowledged it last year (European Parliament, 2019) and has set objectives

1. Introduction

to tackle it by 2050 (European Commission, 2019). In the chemical engineering sector, the Barcelona Declaration (2018) was signed to raise awareness about the importance of the contribution of chemical engineering to solve the Grand Challenges of Engineering (National Academy of Engineering, 2008) and was presented as a call for action.

After analyzing the situation and the prospect for the future, it is vital to take corrective actions to slow down the environmental impact of humankind. Thus, it is key to move toward sustainable resources management. This need has been upheld since the past century by the advocates of sustainable development.

The most frequently quoted definition of sustainable development is the one from the so-called Brundtland Report (World Commission on Environment and Development, 1987):

"Sustainable development is development that meets the needs of the present without compromising the ability of future generations to meet their own needs".

It contains two key concepts:

- the concept of 'needs', in particular the essential needs of the world's poor, to which overriding priority should be given; and
- the idea of limitations imposed by the state of technology and social organization on the environment's ability to meet present and future needs."

Elkington (1997) expanded the concept by defining the three pillars of sustainable development: profit (economically viable), planet (environmentally friendly) and people (social compatible). The triple bottom line is seen as three interdependent pillars that must be taken into account when evaluating the performance of a system.

The concept of sustainability admits an open scope of viewpoints and actions (Hopwood et al., 2005). In the next section, several approaches to the concept of sustainability are presented.

1.2. Approaches to sustainable development

There is a lack of consensus on the definition and application of sustainable development and some of the specific approaches to it (Geissdoerfer et al., 2017; Sauvé et al., 2016). With the aim to narrow the scope of this Thesis and the approaches considered, the next subsections briefly describe the concepts of circular economy, industrial ecology and industrial symbiosis and their relation to the Process Industry.

1.2.1. Circular economy

One of the approaches to the open idea of sustainability that has exponentially gained interest during the past years is the one behind the concept of “circular economy”.

Circular economy opposes to the traditional concept of linear economy as represented in Figure 1.1. The concept was first described by Stahel and Reday (1976) as a tool to substitute manpower for energy from the industrial economics point of view. They assessed closing economic cycles to prevent waste generation, empower the creation of regional jobs, manage resources efficiently and dematerializing industrial economy.

After evaluating its different applications in literature, Geissdoerfer et al. (2017) defined circular economy as "a regenerative system in which resource input and waste, emission, and energy leakage are minimised by slowing, closing, and narrowing material and energy loops. This can be achieved through long-lasting design, maintenance, repair, reuse, remanufacturing, refurbishing, and recycling."

However, several authors (Kalmykova et al., 2018; Kirchherr et al., 2017; Korhonen et al., 2018; Prieto-Sandoval et al., 2018) have stated the inconsistency among this definition and its application in different sectors (e.g. the blurriness among the different approaches to sustainable development and the different terminology employed for similar concepts) and the academic community is moving toward standardizing this concept and its practical implementation. Herein the approach considered in this Thesis focuses on the target of applying this concept to process industries.

1. Introduction

Circular-economy business models can be classified in two groups according to Stahel (2016):

- those that promote reuse and extend service life through repair, re-manufacture, upgrades and retrofits;
- and those that turn old goods into as-new resources by recycling and transforming materials.

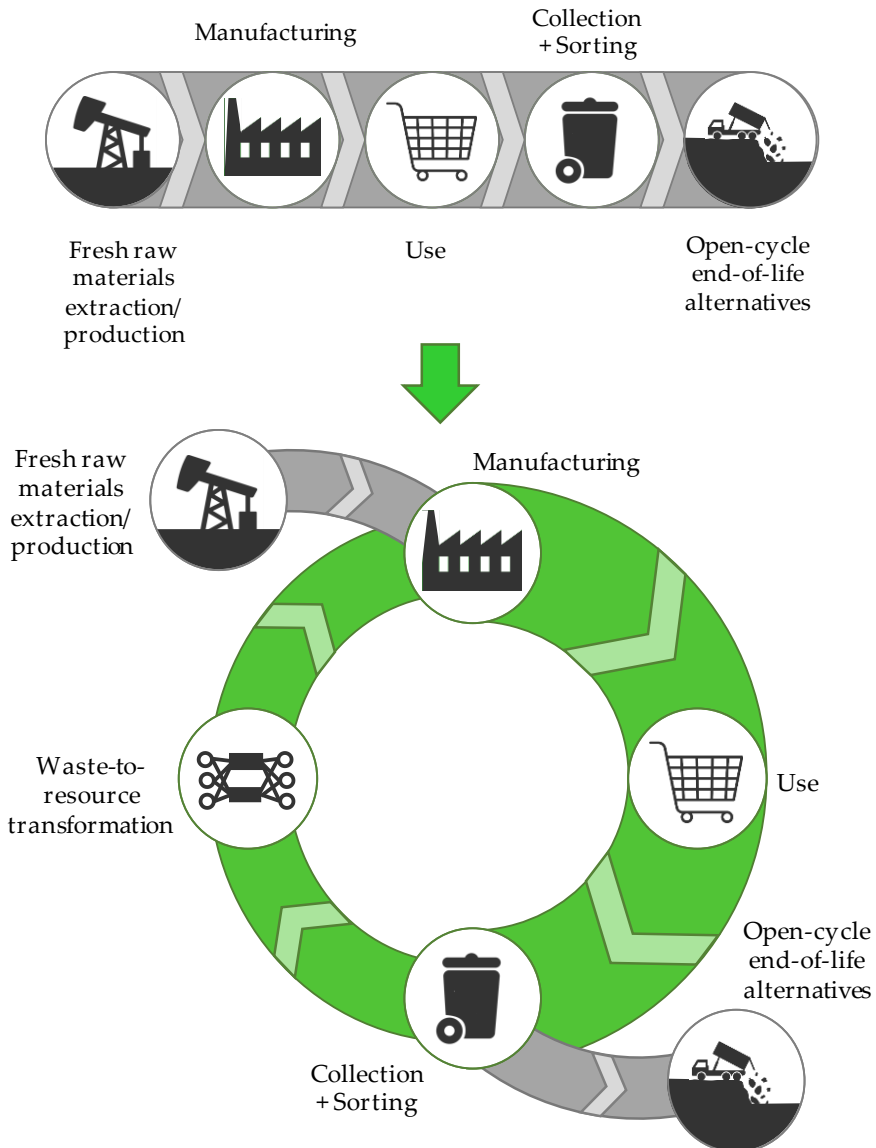

Figure 1.1. Linear vs circular economy.

Nowadays, circular economy is a broad concept with different stakeholders (academics, thought-leaders, administrations, profit and nonprofit organizations, etc.) involved in distinct practical applications.

Among other organizations, the Ellen MacArthur Foundation has invested much effort in fostering the economic opportunities of circular economy and actively collaborates these stakeholders for its implementation (Ellen MacArthur Foundation, 2015, 2014, 2013a, 2013b).

Policymakers are promoting circular economy strategies with regulations and recommendations. Some remarkable examples are the regulations in China (The Standing Committee of the National People's Congress China, 2008) and the European Union's actions (EU Commission, 2014).

Circular economy principles have been implemented in companies, with some successes and failures. Key aspects for an effective implementation include integrated bottom-up and top-down approaches applications and evaluation, regulation and incentives, efficient information exchange and quality consideration (Winans et al., 2017).

According to the Ellen MacArthur Foundation (2013a) the general concept of circular economy has been refined and developed by diverse schools of thought: Regenerative Design, Performance Economy, Cradle to Cradle design, Industrial Ecology and Biomimicry.

1.2.2. Industrial ecology

Frosch and Gallopoulos (1989) established the concept of industrial ecology by comparing industrial systems to natural ecosystems. In their article, they advocate that if waste from an industrial process is fed as raw materials to another, the environmental impact of industry will be reduced.

Erkman (1997) gathered the key elements of industrial ecology found in the literature until that time, concluding that:

- It promotes a systemic, comprehensive, and integrated view of all the components of the industrial economy and their relations with the biosphere.
- It emphasizes the biophysical substratum of human activities, i.e. the complex patterns of material flows within and outside the industrial system, in contrast with current approaches which mostly consider

1. Introduction

the economy in terms of abstract monetary units, or alternatively energy flows.

- It considers technological dynamics, i.e. the long term evolution (technological trajectories) of clusters of key technologies as a crucial (but not exclusive) element for the transition from the actual unsustainable industrial system to a viable industrial ecosystem.

More recently, Allenby (2006) defined industrial ecology as "a systems-based, multidisciplinary discourse that seeks to understand emergent behavior of complex integrated human/natural systems".

1.2.3. Industrial symbiosis

While industrial ecology studies material and energy flows in industrial systems through local, regional, and global scales, industrial symbiosis is a sub-field that focuses on inter-firm level (Chertow, 2000).

According to Chertow (2000), "industrial symbiosis engages traditionally separate industries in a collective approach to competitive advantage involving physical exchange of materials, energy, water, and by-products". She also stated that the keys to industrial symbiosis are "collaboration and the synergistic possibilities offered by geographic proximity". According to the 3–2 heuristic logic developed by Chertow (2007), an industrial symbiosis network is defined as a network in which there are at least three different firms exchanging at least two different types of waste.

The main advantages of sharing resources include enhancing material and energy conservation, reducing the costs for the acquisition of fresh raw materials and treatment of side products, and reducing the environmental footprint.

The practical realization of industrial symbiosis are the so-called eco-industrial parks, where a community of business cooperate with each other thanks to their geographical proximity. Kalundborg, in Denmark, is one of the earliest examples of successful eco-industrial parks where an industrial symbiosis network has evolved over time to exchange and share material and energy resources among various production facilities (e.g., gypsum, cement, steel, power, pharmaceuticals, and wallboard) (Ehrenfeld and Gertler, 1997).

Figure 1.2 depicts the state of the symbiotic connections in Kalundborg in 2015.

The concept has spread throughout the globe and there are numerous successful examples. The existing industrial ecosystems are organized within a community (e.g. Kalundborg in Denmark, Guayama in Puerto Rico, Shenzhen in China) or within a broader regional area (e.g. Styria in Austria, Tianjin Economic Development Area in China, Rotterdam Harbor in The Netherlands) as analyzed by Chertow (2012).

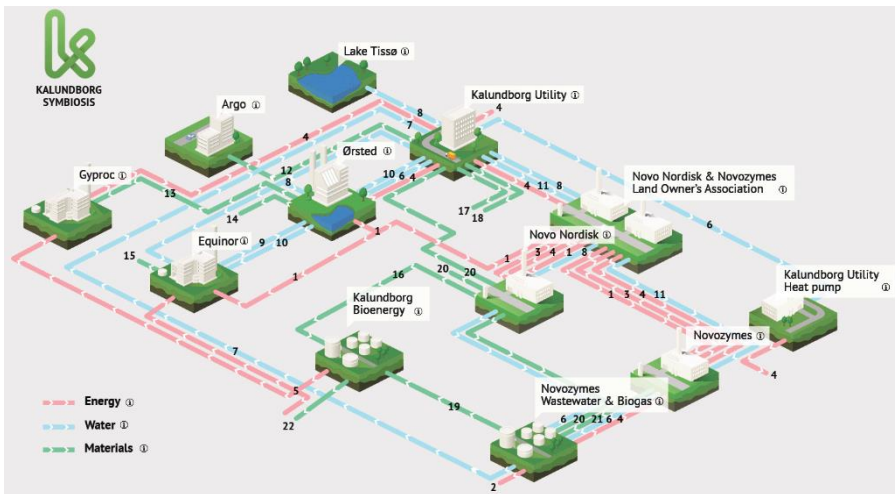

Figure 1.2. Diagram of the Kalundborg symbiosis system. (Retrieved from: <http://www.symbiosis.dk>)

1.3. Research scope and objectives

Among the mentioned approaches, the focus of interest of chemical engineering would be industrial symbiosis, which is centered on the industrial application of the concept. However, the frontiers between the concepts of circular economy and industrial symbiosis remains to some extent fuzzy. Both circular economy and industrial symbiosis have in common the major target of promoting resource recovery. However, both approaches address this goal from a different perspective. While circular economy focuses on closing the loop of materials, which implies the upcycling of resources, industrial symbiosis fixes its attention on resource (material and energy) exchange among industries, regardless of the resulting system being linear or circular. Hence,

1. Introduction

the focus of this thesis is going to be the application of circular economy principles from a wider point of view.

The main advantages of the different approaches to sustainable development described above include enhancing material and energy conservation, reducing the costs for the acquisition of fresh raw materials and treatment of side products, and decreasing the environmental footprint. These benefits are increased if, apart from direct waste-to-resource matching, transformation opportunities are also considered as a way to convert otherwise unusable waste into new profitable materials. In this regard, new technologies like chemical recycling are emerging as promising options to close the loop of materials.

Efficiently exploiting such approaches (i.e., network and process design and operation choices) is challenging mainly due to the number of actors involved (i.e., the different industries that take part in the system, the requirements from the administration and other third parties) as well as the number of flows to manage (i.e., materials and energy) and their potentially different nature. In particular, decision-making in the process industries is further challenged by the low maturity of some chemical recycling technologies, which despite this uncertainty need to be contemplated while assessing future scenarios and designing next generation process networks.

This Thesis aims at providing a set of models and tools to support in the decision-making process of closing material cycles in process systems through the implementation of waste-to-resource technologies from a circular economy perspective. This general goal can be broken down into three objectives:

- To build efficient models for the representation of waste-to-resource technologies and its inclusion in process networks.
- To identify comprehensive criteria to quantify the performance of waste-to-resource processes and material networks.
- To develop practical strategies for the optimization of these models according to the defined criteria.

1.4. Thesis outline

This Thesis has been structured in order to introduce progressively the contributions to the implementation of circular economy principles in process systems. It consists of five parts as represented in Figure 1.3.

Part I, in addition to this introductory chapter, includes in Chapter 2 a review of the state of the art of optimization methods applied to solve industrial symbiosis and circular economy problems. The tools required are presented in Chapter 3 and the problem statement and the optimization framework to solve it are introduced in Chapter 4.

Part II presents a framework to determine whether the application of circular economy principles in the chemical industry is environmentally and economically beneficial. This is illustrated through the case of ethylene recovery from polyethylene waste through its chemical recycling. Chapter 5 describes the process followed to characterize waste-to-resource technologies in terms of material and energy flows, equipment sizing, fixed and variable costs and profit from sales, and environmental impact. Chapter 6 shows the application on individual echelons, through the techno-economic and environmental comparison of this circular approach in front of the business-as-usual method to produce ethylene and the alternative end-of-life treatments for waste polyethylene, while its effect on the supply chain is analyzed in Chapter 7.

Part III describes some of the groundwork tasks required for the development of the optimization models presented in part IV. The definition of an ontological framework to classify the information in a structured manner is provided in Chapter 8. Chapter 9 presents a framework and a procedure for the targeting of material exchange in a certain scenario.

Part IV develops the proposed decision-making framework at the strategic and tactical hierarchical levels. An optimization model for the synthesis of circular economy networks is presented in Chapter 10, while Chapter 11 addresses the detailed synthesis of a process selected in the network resulting from the previous chapter.

Finally, Chapter 12 in Part V summarizes the conclusions derived from the research developed in this Thesis and points out the future work lines to be explored.

1. Introduction

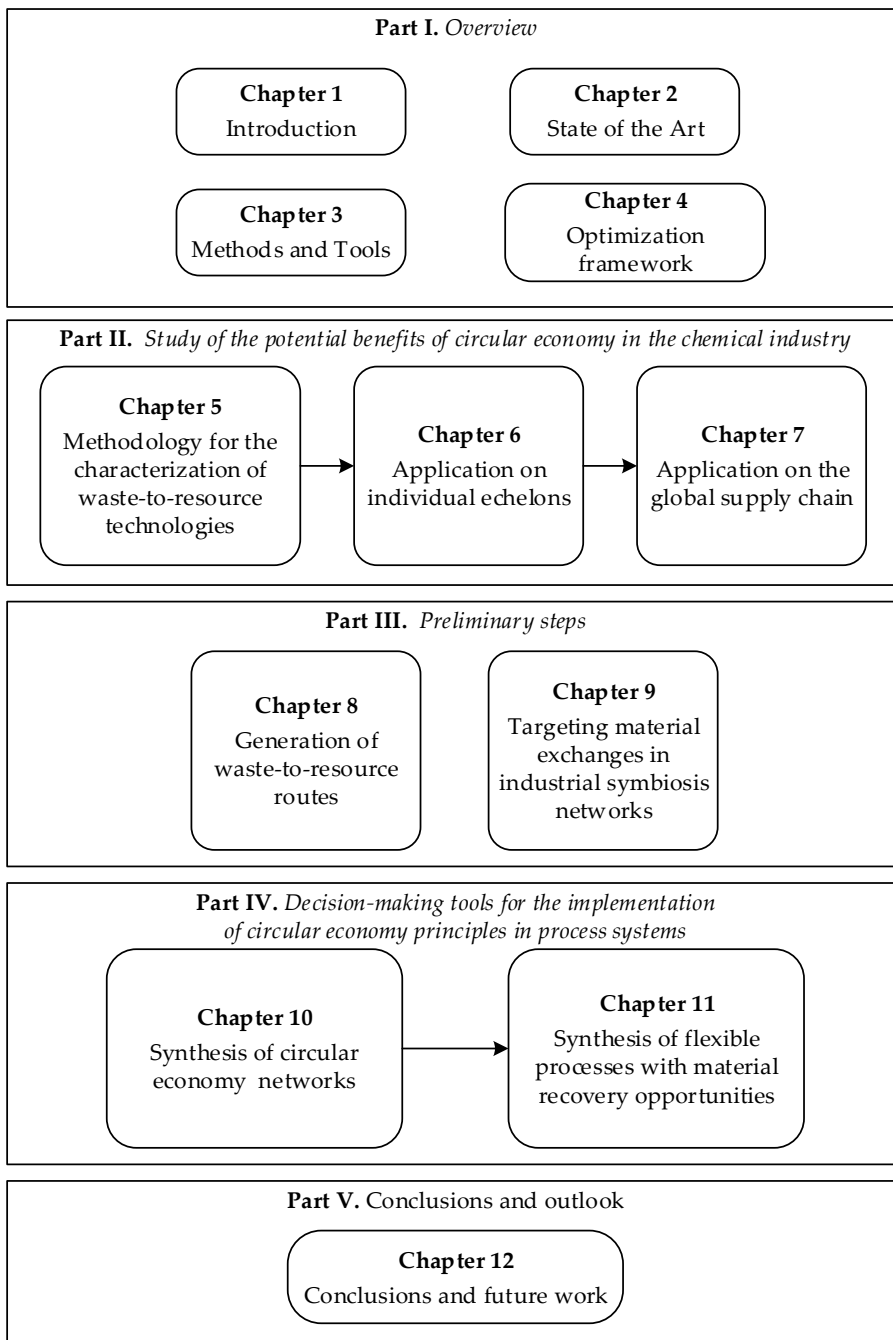

Figure 1.3. Thesis outline.

2.1. Sustainability in Process Systems Engineering (PSE)

The previous sections presented different approaches to sustainability from the more general (sustainable development and circular economy) to the more practical (industrial ecology and industrial symbiosis). These approaches share common points, such as environmental concerns, and the need to regenerate and restore resources to allow economy running in the long term.

Although the concept of sustainability, and especially circular economy, has gained momentum during the last years, there is previous valuable knowledge that aids in the pursue of an environmentally-friendly future. The Process Systems Engineering (PSE) community has been aware of this need to move toward more sustainable products, processes, and supply chains and has been working on addressing them since the late 1980s. Below are listed some of the more well-known strategies in this regard:

- At the process level, process integration is a holistic approach for the design and operation of more efficient processes that emphasizes the unity of the process (El-Halwagi, 2006, 1997). It can be divided into mass integration (El-Halwagi and Spriggs, 1998) and energy integration (Linnhoff and Hindmarsh, 1983; Yee et al., 1990).

2. State of the art

- Process intensification follows process integration in the enhancement of process design. It looks for compact, safe, energy-efficient, and environment-friendly sustainable processes (Stankiewicz and Moulijn, 2000).
- Following the trend but at the supply chain level, closed-loop supply chains is the most similar concept to industrial symbiosis. The focal point of closed-loop supply chains is in the concept of closing the cycle of resources in the context of a supply chain (Guide and Wassenhove, 2009; Salema et al., 2010; Souza, 2013).
- From a broader perspective, enterprise-wide-optimization explores the optimization of the operations of supply, manufacturing and distribution activities of a company so as to reduce costs and inventories (Grossmann, 2005). It exploits the use of computing tools and process models to integrate the information and decision-making across the different levels of the supply chain, including planning, scheduling, real-time optimization and inventory control. This broad focus is similar to the one required to close the loop of materials in circular economy.
- Being applicable to all levels and in parallel to the aforementioned techniques, Life Cycle Assessment is a tool to evaluate the environmental impact of a product throughout its lifespan which has been widely used in process systems applications (Guillén-Gosálbez and Grossmann, 2009; Gutiérrez-Arriaga et al., 2014).

Even though these strategies have been widely used in the past years, there are still numerous challenges to face in the coming years. Grossmann (2004) claimed in his challenges for the new millennium that sustainability needs a bolder and more creative approach. He advocated for process intensification and stronger interaction between product and process in life-cycle assessment the most promising alternatives. This becomes even more necessary when taking into account the current situation of the exertion of the environment, resource scarcity and waste accumulation among others. In this light, the Grand Challenges of Engineering (National Academy of Engineering, 2008) and the Sustainable Development Goals (United Nations, 2016) provide further guidance. For further detail, Avraamidou et al. (2020)

recently published a comprehensive review on tools developed by PSE and how they can help solving the challenges of circular economy.

2.2. Literature review

2.2.1. Keywords and trends

Since the term industrial symbiosis was coined in the late 80s, several authors have seen the benefits of linking it to the knowledge on process optimization. Circular economy appeared later but has gained popularity fast. The growing interest on the concepts can be seen in the trend of articles published by year (Figure 2.1). The data for this plot has been retrieved from Scopus, by performing a search of the concepts: “industrial symbiosis” (or “eco industrial park”, or “inter plant integration”) and “optimization” to update the review by Boix et al. (2015) and correspondingly “circular economy” and “optimization”. The searches resulted in a total of 150 publications concerning industrial symbiosis and 157 about circular economy. While the number of research items on industrial symbiosis has grown steadily from 2000, the ones related to circular economy have exponentially escalated during the past decade.

While the search on industrial symbiosis, by definition of the term, gave works clearly related to the field of chemical engineering, the contributions on circular economy are from a wide range of fields and diverse approaches to optimization. Thus, only the works related to industrial symbiosis are analyzed below.

The contributions considered in this analysis address the optimization of networks to exchange water, energy and/or materials. Figure 2.2 shows the number of publications that consider each type of network. While water and energy networks are optimized in a 35% and a 41% of the publications, respectively, material sharing is only considered in a 25% of the articles.

2. State of the art

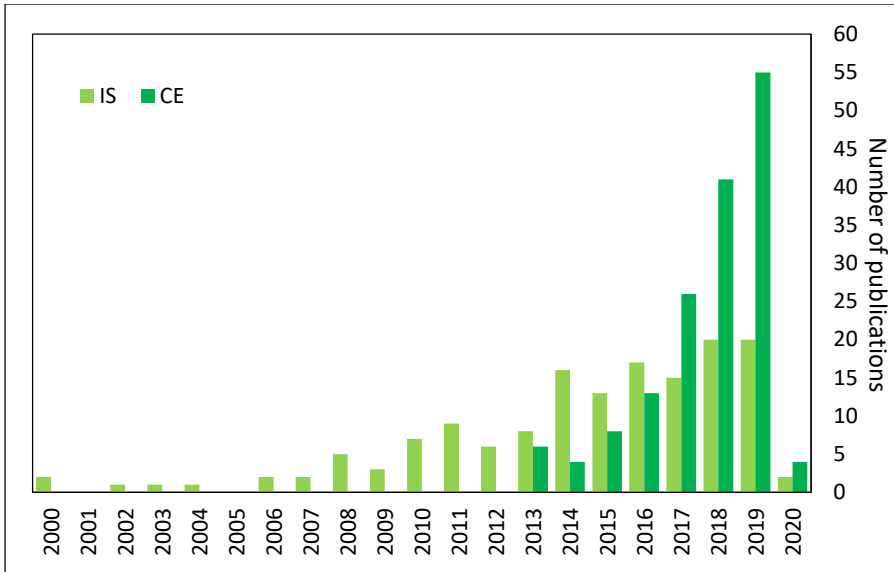

Figure 2.1. Number of publications per year with the search: in light green “industrial symbiosis” (or “eco industrial park”, or “inter plant integration”) and “optimization” and in dark green “circular economy” and “optimization” (Source of the data: Scopus).

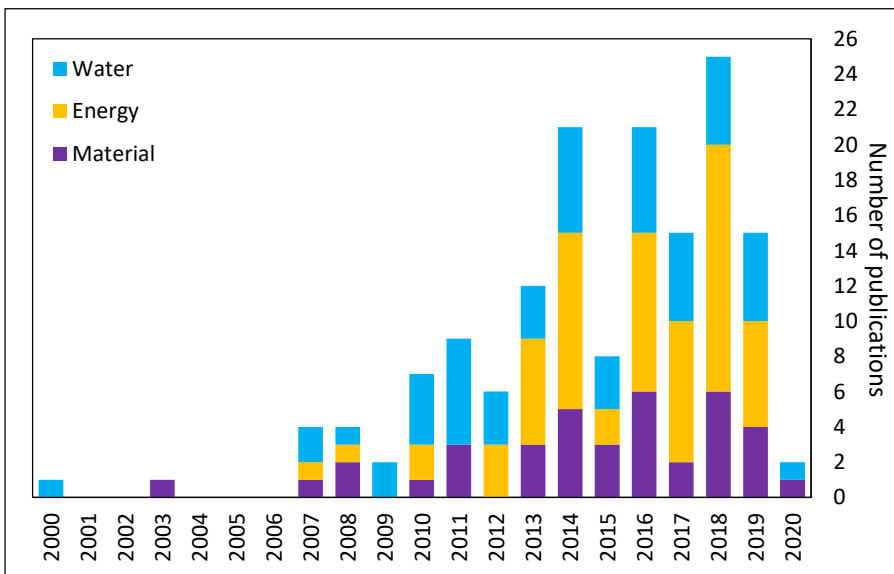

Figure 2.2. Number of publications per year addressing water, energy or material networks optimization.

Within the fraction that considers material exchange, only a 57% provides a general methodology to tackle different problems. Thus, the other 43% can hardly be applied, as their optimization model is only applicable to a particular case study. It should be noted that only 4 of them considered the possibility of transforming waste into added-value products to increase the materials degree of reuse.

As confirmed by figures, water network is the most studied in literature. Yoo et al. (2007) proposed a division of works in two approaches according to whether they optimize networks through pinch technology (e.g. Kim et al. 2008; Leong et al. 2017) or mathematical programming (e.g. Lovelady and El-Halwagi 2009; Rubio-Castro et al. 2011). In this kind of works, is essential to ensure that water contaminants are handled properly. Other works include: Aguilar-Oropeza, Rubio-Castro, and Ponce-Ortega (2019) worked on finding the utopian point for water recycling and reuse; Aviso (2014) developed a robust optimization model for stochastic modelling; Huang et al. (2019) proposed a stochastic model for the design of industrial water desalination; Jiang et al. (2019) considered the joint use of water utility system; Montastruc et al. (2013) study the flexibility of water networks in industrial symbiosis; O'Dwyer et al. (2020) take into account spatial effect on the network design; Tiu and Cruz (2017) focus on water quality considerations; Xu et al. (2019) study fault propagation in water networks.

The works on energy optimization in industrial symbiosis systems can also be classified in pinch analysis (e.g. Hiete, Ludwig, and Schultmann 2012) and mathematical programming (e.g. Andiappan, Tan, and Ng 2016). The main drawbacks for energy sharing are: the difficulties of storing electricity and balancing production and demand, the investment cost required for extra equipment (e.g. heat exchangers and turbines), and the losses produced when heat is transported far (Boix et al. 2015). This is why efforts are still devoted to the optimization of energy exchange networks and their integration (Aziz and Hashim, 2019; Leong et al., 2017a). Zhang et al., (2017) consider knowledge management for energy utilization. Bütün, Kantor and Maréchal, (2019) include spatial considerations. Knudsen, Kauko and Andresen, (2019) design a model for surplus-heat allocation;

In addition, the reduced amount of works addressing the optimization of material exchange is limited to specific case studies, and the idea of general

2. State of the art

methodologies applicable to other systems has been hardly explored. Some examples of the works on specific case studies include design models for palm oil industry (Mohamad Shukery et al., 2016; Ng et al., 2014) and bioethanol production (Gonela et al., 2015; Gonela and Zhang, 2014). Focusing on the complexities of the generic problem of resources transformation and exchange, Maillé and Frayret (2016) developed a MILP formulation to optimize by-product flows, synergy configurations, and investment decisions in eco-industrial networks; Ren et al. (2016) developed a multi-objective model based on emergy indexes and Tan et al. (2016) considered cooperation between industries. More recently, Al-Fadhli, Baaqeel, and El-Halwagi (2019) extended their previous works on targeting Carbon-Oxygen-Hydrogen symbiosis networks by adding modular design and natural resource limitations. The works by this research group (Noureldin and El-Halwagi, 2015; Panu et al., 2019; Topolski et al., 2018) have brought a consistent framework for material exchange centered in EIPs. The difficulties in optimizing material networks still lie on the multiplicity of the materials produced, the importance of satisfying its strict quality constraints and the design of necessary equipment.

2.2.2. Performance assessment and objective function

Another concept that deserves attention is the characterization of the objective function. In Figure 2.3, the number of publications that consider economic, environmental and social objectives or constraints per year are represented.

Economic aspects are considered in more than 89% of the publications. However, environmental constraints are taken into account only by 38% and social by just 2%. This could be an unexpected result, as industrial symbiosis advocates for sustainability and environmental concerns should be regarded when designing resource sharing networks.

Even though multi-objective is a common practice in Process Systems Engineering, only a 29% of the publications analyzed involve multi-objective decisions. This can be due to the fact that handling conflicting objectives increases the complexity of models that already have to deal with intricate formulation, because of the size of problems modelling networks.

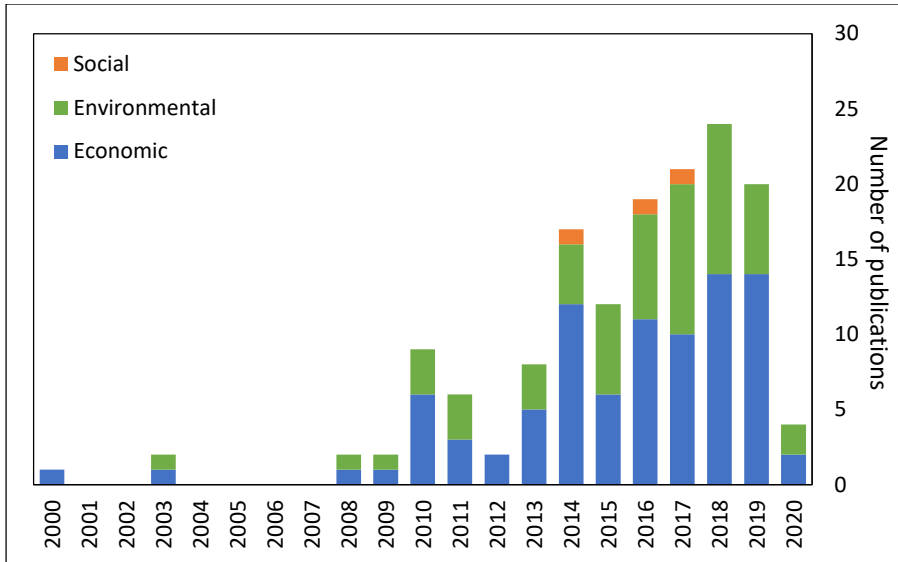

Figure 2.3. Number of publications per year regarding economic, environmental or social objectives.

The most used economic objective is the net present value (Andiappan et al., 2016; Kolluri et al., 2016), but cost minimization is also common in literature (Pan et al., 2016; Ramos et al., 2016). As industrial symbiosis involves several stakeholders, it is important to consider the gains of each individual company when optimizing. Boix et al. (2012) introduced a constraint to force equal gains for each company and Tan et al. (2016) proposed a cooperative game model to pooling the profits and sharing them among the partners.

Environmental impacts are most frequently evaluated through Life Cycle Assessment (Gerber et al., 2013). In addition, the majority of the publications that consider multi-objective optimization look to improve economic and environmental objectives. Tiu and Cruz (2017) took into account the volume and quality of water when minimizing an eco-industrial park's environmental impact. Ren et al. (2016) also dealt with multi-objective optimization by adding sustainability criteria through a Particle Swarm Algorithm. Leong et al. (2017) tackled the problem of resource sharing as a multi-objective problem by an analytic hierarchy process approach. Maillé and Frayret (2016) evaluated the economic and environmental sustainability of potential synergies in order to analyze the cost/saving trade-off of a multi-period network of by-product synergies.

2. State of the art

Social aspects are mainly added to systems with economic objectives. For instance, Ng et al. (2014) evaluated the inherent safety of entire industrial symbiosis system. They looked for a network configuration with the maximum individual economic interests and minimum individual inherent safety.

2.2.3. Data management

Finally, an important issue is data collection and management, where some works have focused on developing databases to store data and detect possible synergies. The complexity of industrial symbiosis systems can be handled more easily with systematic storage and administration of its data. (Álvarez and Ruiz-Puente, 2016; Cecelja et al., 2015; Zhang et al., 2017b)

2.2.4. Challenges

Boix et al. (2015) performed a detailed review of the state of the art of optimization in industrial symbiosis. The topics they found to be still lacking to be studied in literature are listed below:

- Cooperation at the process level in: transformation of wastes into by-products, exchanges of knowledge, and human and technical resources.
- Energy sharing to: interplant energy flows management and optimization/multi-objective optimization of energy networks.
- Material sharing: optimization of resource networks and transformation.
- Integrated optimization of water/material/energy sharing.
- Multi-objective optimization with economic, environmental, social and topological criteria.
- Dealing with data collection and management.
- Base decisions on quality of the streams involved.

There have been interesting studies in the field. However, most of the challenges proposed by Boix et al. (2015) have not been achieved yet. There

is still a gap in the optimization of material exchange networks and integrated systems to share water, energy and materials. More specifically, the possibility of transforming waste streams before recycling them has not been fully addressed even though it could lead to great advances in the field of industrial symbiosis. The aim of this Thesis is to overcome some of those limitations. The specific objectives to attain this will be defined in the following section.

2.3. Trends and challenges

As identified in the previous sections, there are still some challenges to be faced in the optimization of circular economy networks. Hence, it is important to work on integrated solutions that increase the extent to which resources are reused and recycled. The main purpose of this Thesis is to develop optimization tools to aid the decision-making process in industrial symbiosis. So, the three main objectives identified in section 1.3 can be further developed as follows:

- To build models for the implementation of material sharing in process systems including of waste-to-resource technologies and its inclusion in process networks.
 - To formulate a model that identifies the optimal network encompassing potential waste-to-resource processes that could be implemented to close the loop between waste producers and resource consumers.
 - To build a modeling approach for the optimal synthesis of the processes resulting from the network optimization.
 - To identify and address the main sources of uncertainty in processes and networks and incorporate them into the model.
- To identify a set of comprehensive criteria to quantify the performance of waste-to-resource processes and material networks.
 - To develop methods to perform a complete techno-economic assessment of the considered transformation processes.

2. State of the art

- To develop methods to implement a thorough assessment of the environmental impact of said processes.
- To develop methods to identify whether the industrial implementation of waste-to-resource is beneficial according to these criteria.
- To develop strategies for the optimization of these models according to the defined criteria under different conditions.
 - To implement methods for the multi-objective optimization techniques to assess the economic and environmental performance of the analyzed processes or networks.
- To implement and validate all these models and strategies in case studies that are relevant for the process industry.

Chapter 3

Methods and tools

3.1. Introduction

In this section, the background of the methods and tools used in the development and implementation of the procedures presented in this Thesis are described.

Several approaches to modeling have appeared over the years. Foss and Lohmann (1998) characterized the modeling process including eight steps: problem statement and initial data collection, modeling environment selection, conceptual modeling, model representation, implementation, verification, documentation and model application. More recently, Albright and Winston (2012) added optimization to the structure with their seven-step process consisting of: problem definition, data collection, model development, model verification, optimization and decision making, model communication to management, model implementation. A version of this second method, but excluding the three last steps, has been followed in this Thesis. First steps consist of formulating the problem and acquiring data to build an illustrative case study. The model is built and tested with the case study. Finally, it can be optimized to aid in the decision-making process.

3.2. Modeling and simulation

Marquardt (1996) classified modeling tools in sequential-modular and equation-oriented approaches. While the first ones address modeling in the flow-sheet level and consider separate process units, the second type are programmed in a modelling language and consider all the equations simultaneously.

3.2.1. Sequential-modular

In a sequential-modular approach to modeling, the different units of a process are solved sequentially. They are intuitive to build and robust to solve, but its directionality and the complicated convergence of recycles reduce its options for optimization.

Aspen Plus is a commercial simulation software developed by AspenTech, whose start dates back to the early 1980s. It has a wide range of programmed thermodynamic models and integrated tools for economic evaluation, equipment design, energy integration and safety analysis.

3.2.2. Equation-oriented

On the other hand, equation-oriented models are more suitable for optimization, due to the level of control of the equations they offer. All the equations are solved simultaneously, making it more computationally challenging. The challenge in solving this type of models is the numerical complexity, which requires to provide good initial guesses.

When working with equation-oriented models, processes are typically represented as superstructures (Papoulias and Grossmann, 1983). They offer numerous opportunities both in terms of modeling and solution strategy. Some of these techniques are discussed in the next section.

3.3. Mathematical programming

Mathematical programming is a branch of management science that concerns the optimum allocation of limited resources among competing activities, under a set of constraints imposed by the nature of the problem being studied (Bradley et al., 1977).

A mathematical program is composed of an objective function, the variables to be determined and the constraints that should be satisfied, and it can be generally represented as:

$$\min Z = f(x, y) \quad (3.1)$$

$$\text{s. t. } h(x, y) = 0 \quad (3.2)$$

$$g(x, y) \leq 0 \quad (3.3)$$

The classical classification splits models for the linearity/non-linearity of its equations and its discrete/continuous variables. Biegler and Grossmann (2004) proposed a more specific classification including the types: linear programming (LP) and its variations linear complementarity problem (LCP) and quadratic programs (QP), nonlinear programming (NLP), mixed-integer programming (MILP) and particularly mixed-integer nonlinear programming (MINLP), global optimization (GO), derivative free optimization (DFO) and its subfields simulated annealing (SA) and genetic algorithms (GA), and conic linear programming (CLP). They represented them in the tree in Figure 3.1.

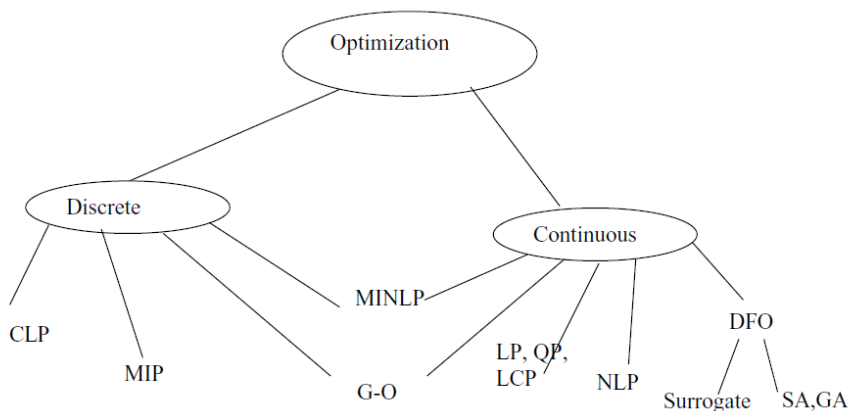

Figure 3.1. Tree of classes of optimization problem by (Biegler and Grossmann, 2004).

Models are solved through solver engines. The selection of the proper Solver will be given by the type of model.

3.3.1. General disjunctive programming

Generalized disjunctive programming (Raman and Grossmann, 1994) is an alternative approach for the representation of mixed-integer optimization problems. It consists of a systematic and intuitive way to formulate models by exploiting the inherent logic structure of the problem with models consisting of algebraic constraints, logic disjunctions and logic. It can be formulated as:

$$\min Z = f(x) + \sum_{k \in K} c_k \quad (3.4)$$

$$\text{s. t. } g(x) \leq 0 \quad (3.5)$$

$$\bigvee_{i \in D_k} \begin{bmatrix} Y_{ik} \\ r_{ik}(x) \leq 0 \\ c_k = \gamma_{ik} \end{bmatrix} \quad \forall k \in K \quad (3.6)$$

$$\Omega(Y) = True \quad (3.7)$$

$$x^{lo} \leq x \leq x^{up} \quad (3.8)$$

$$x \in R^n, c_k \in R^1, Y_{ik} \in \{True, False\} \quad (3.9)$$

where f is a function of the continuous variables x in the objective function, g belongs to the set of global constraints, the disjunctions $k \in K$, are composed of a number of terms $i \in D_k$, that are connected by an or operator (\vee). Set of Boolean variables Y_{ik} apply to the inequalities $r_{ik}(x) \leq 0$ and cost calculations c_k . $\Omega(Y) = True$ are logic propositions. (Grossmann and Ruiz, 2012)

3.3.2. Multi-objective optimization

In real situations, decision makers have to simultaneously deal with several objectives, such as capital and operating costs, use of utilities, quality, efficiency, environmental effects, process safety or robustness. Thus, it is important to go beyond economic objectives when optimizing systems. The appropriate objectives for a particular application are often conflicting, which means achieving the optimum for one objective requires some compromise

on one or more other objectives. Some examples of sets of conflicting objectives are: capital cost and operating cost, selectivity and conversion, quality and conversion, profit and environmental impact, and profit and safety cost. (Rangaiah, 2009)

Therefore, multi-objective optimization problems do not provide a unique solution, but a set of optimal solutions for the different trade-offs between the objectives, called Pareto solutions (Bhaskar et al., 2000). Rangaiah (2009) performed a review of the different multi-objective optimization methods, which is summarized in Figure 3.2. When assessing the method to use for specific problems, it is essential to consider the performance of each approach, as analyzed by Zitzler et al. (2003).

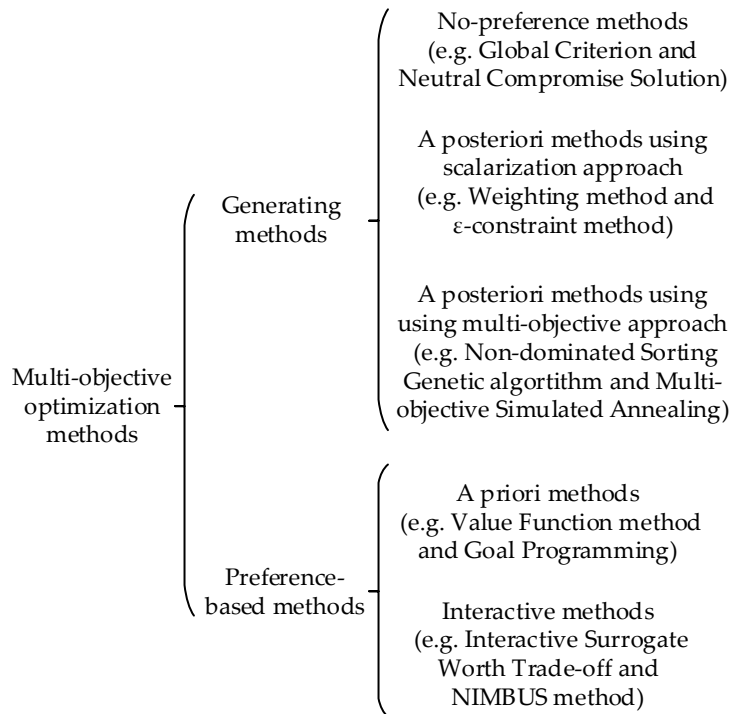

Figure 3.2. Methods to solve multi-objective optimization problems (adapted from Rangaiah, 2009).

3.3.3. Uncertainty management

The representation and effect of uncertainty on the different fields of Process Systems Engineering have been widely studied since the middle of last century. Since the early works of Beale (1955) and Dantzig (1955), decision-making under uncertainty has been addressed in a large number of problems in production planning and scheduling, location, transportation, finance, and engineering. Uncertainty can affect the prices of fuels, the availability of electricity, and the demand for chemicals (Sahinidis, 2004).

Pistikopoulos (1995) proposed a classification of uncertainty based on the nature of its source:

- *Model-inherent uncertainty*: includes kinetic constants, physical properties and transfer coefficients. This information is usually obtained from experimental and pilot-plant data; a typical description form can be supplied via either a range of possible realizations or some approximation of a probability distribution function.
- *Process-inherent uncertainty*: includes flowrate and temperature variations, stream quality fluctuations, etc. This category can be described by a probability distributional form obtained from on-line measurements. Any desired range of these uncertain parameter realizations could in principle be achieved through the implementation of a suitable control scheme.
- *External uncertainty*: includes feedstream availability, product demands, prices and environmental conditions. Forecasting techniques based on historical data, customer orders and market indicators are usually used to obtain approximate ranges of uncertainty realizations or a probability distributional form.
- *Discrete uncertainty*: includes equipment availability and other random discrete events. A discrete probability distribution function can commonly be obtained from available data and manufacturer's specifications.

The main approaches to optimization were summarized by Sahinidis (2004):

- *Stochastic programming*: includes recourse models, robust stochastic programming, and probabilistic models.

- The most frequently used method to tackle uncertainty are Two-stage stochastic optimization models, recourse models that minimize the sum of the costs of the first stage (considering variables that have to be decided before uncertain parameters reveal themselves) and the expected cost of the second stage (with variables that have to be decided after knowing the value of uncertain parameters). (Ahmed and Sahinidis, 1998)
- Robust stochastic programming is a variation of resource-based models that consider risk through the consideration of variability in the costs of the second stage. (Mulvey et al., 1995)
- Probabilistic models focus on minimizing the reliability of the system, expressed as a minimum requirement on the probability of satisfying constraints. (Prékopa, 1995)
- *Fuzzy programming*: flexible and possibilistic programming.
- While in stochastic programming uncertainty is modeled through discrete or continuous probability functions, fuzzy programming considers random parameters as fuzzy numbers and constraints as fuzzy sets. (Zimmermann 1978)
- Flexible programming considers fuzzy constraints (Zimmermann 1991) and possibilistic programming deals with uncertainty in constraint coefficients (Tanaka and Asai, 1984).
- *Stochastic dynamic programming*: allows dealing with multi-stage decision-making by optimizing different subproblems of the entire time horizon at the same time (Bellman, 1957).

Some recent applications related to the topic of the Thesis are the works on optimization of closed-loop supply chains under uncertainty (Cardoso et al., 2016; Zeballos et al., 2016). The work by Hwangbo, Lee, and Han (2017) deals with uncertainty in utilities sharing.

As affirmed in the state of the art, few works can be found that deal with uncertainty in industrial symbiosis. The different sources of uncertainty in industrial symbiosis networks will be studied throughout the development of the Thesis. After classifying them for the nature of its source, the most appropriate method to tackle it will be implemented.

3.3.4. Software

After being formulated, mathematical programming problems are implemented in advanced modeling languages and solved through optimization solver engines. GAMS, AIMMS and AMPL are some commercial tools that have been historically used in the PSE field. However, open source alternatives such as Pyomo have been gaining popularity during the previous years. In this Thesis, GAMS and Pyomo are used according to the need for different applications.

3.3.4.1. GAMS

The General Algebraic Modeling System (GAMS) is an algebraic modeling language to represent and solve mathematical programming problems (GAMS Development Corporation, 2020). It started as a project funded by The World Bank in the early 1980s (Bisschop and Meeraus, 1982) although now belongs to GAMS Development Corporation.

It has been widely used as a modeling and optimization tool in PSE and has a broad community of users throughout the world. One of its major advantages are its high compatibility among different versions and the flexibility it offers for model adaption and solution.

3.3.4.2. Pyomo

Pyomo is an open source software package for modeling and solving mathematical programs in Python (Hart et al., 2011). It was originally developed by researchers in the Center for Computing Research at Sandia National Laboratories and is a COIN-OR project.

Because of its open source nature, it has gained substantial popularity during the past years, and has a wide community of online users who share and update this diverse set of optimization capabilities for formulating, solving, and analyzing optimization models. However, the fast-paced evolution of Python leads to rapid model obsolescence, forcing the user to constantly update its codes.

3.4. Life cycle assessment

The environmental impact of the processes analyzed in this Thesis is evaluated through Life Cycle Assessment (LCA). The guidelines to perform it are described in the standard ISO 14040:2006 (International Organization for Standardization, 2006), which divides an LCA in four phases: the definition of the goal and scope of the LCA, the life cycle inventory analysis (LCI), the life cycle impact assessment (LCIA), and the life cycle interpretation. These steps are further described in Chapter 5.

3.4.1. Software, databases and solution methods

Three tools are required to perform a LCA: a software for impact evaluation, a database with the environmental impacts of predefined processes and a method for the evaluation. In this Thesis, SimaPro is used for the calculations, Ecoinvent v3.4 as database, and ReCiPe 2016 as the impact evaluation method. They are briefly described below.

3.4.1.1. SimaPro

SimaPro (Goedkoop et al., 2016) is a LCA software package developed by PRé Sustainability that encompasses: connection with environmental impact databases, methods for impact evaluation and analysis tools. According to its developers, its key features are: easily model and analyze complex life cycles in a systematic and transparent way; measure the environmental impact of your products and services across all life cycle stages; and identify the hotspots in every link of the supply chain.

3.4.1.2. Ecoinvent v3.4

Ecoinvent v3.4 database (Wernet et al., 2016) is used to gather the impact data associated with the material and energy flows that are out of the boundaries of the process. The Ecoinvent database started collecting impact data in the 1990s, and is currently the most complete LCI database.

3. Methods and tools

3.4.1.3. ReCiPe 2016

ReCiPe 2016 is a life cycle impact assessment method to quantify environmental performance of the processes analyzed (Huijbregts et al., 2017).

It resumes the life cycle inventory results into 18 midpoint indicators (Global warming, Stratospheric ozone depletion, Ionizing radiation, Ozone formation - Human, Fine particulate matter formation, Ozone formation - Terrestrial, Terrestrial acidification, Freshwater eutrophication, Terrestrial ecotoxicity, Freshwater ecotoxicity, Marine ecotoxicity, Human carcinogenic toxicity, Human non-carcinogenic toxicity, Land use, Mineral resource scarcity, Fossil resource scarcity and Water consumption) and three endpoint indicators (effect on human health, ecosystems and resources).

Optimization framework

This chapter introduces the general problem statement, the proposed holistic approach for the optimal synthesis of material exchange from a circular economy perspective and the application used to validate it.

4.1. General problem statement

The problem to be addressed can be stated as follows.

Given are:

- a set of waste streams with known composition that come from different companies and must be processed,
- a set of raw materials required as inputs for the processes of the same or other companies,
- a set of available treatment technologies with a defined technology readiness level,
- a set of equipment used in each treatment technology,
- and all related economic factors and environmental impacts (for purchased waste, waste-to-resource processes and required raw materials).

4. Optimization framework

Decisions include:

- the optimal configuration of the resource exchange network including
 - flows of waste sent to disposal, direct reuse or recycling,
 - how to satisfy the demand of raw materials (from fresh outsourced compounds or waste transformed into resources),
 - flows of outsourced compounds as reactants or to be directly sold,
 - and all the corresponding flowrates and compositions,
- and the optimal synthesis of the waste-to-resource processes involved in the network consisting of
 - the path to convert these materials into the most valuable resources, taking into account current market requirements.

This definition can turn out complex to solve, as it involves decisions from two different hierarchical levels (the network at the strategical level and the process synthesis at the tactical level).

4.2. Framework for the synthesis of material exchange networks

Figure 4.1 pictures the scheme of the proposed framework for the synthesis of material exchange networks.

First, the problem should be stated (see section above) according to the available data in terms of waste generation, raw material requirements and information of waste-to-resource processes.

The processes to be considered for waste transformation can be well-established or based on non-matured technologies under development. In any case, it is crucial to ensure comparability among information from different sources. Thus, they should be characterized in a systematic way to obtain the data required at subsequent steps (Chapter 5). This data is then used to create waste-to-resource routes that prioritize these routes that go from available sources of waste to required raw materials (Chapter 8).

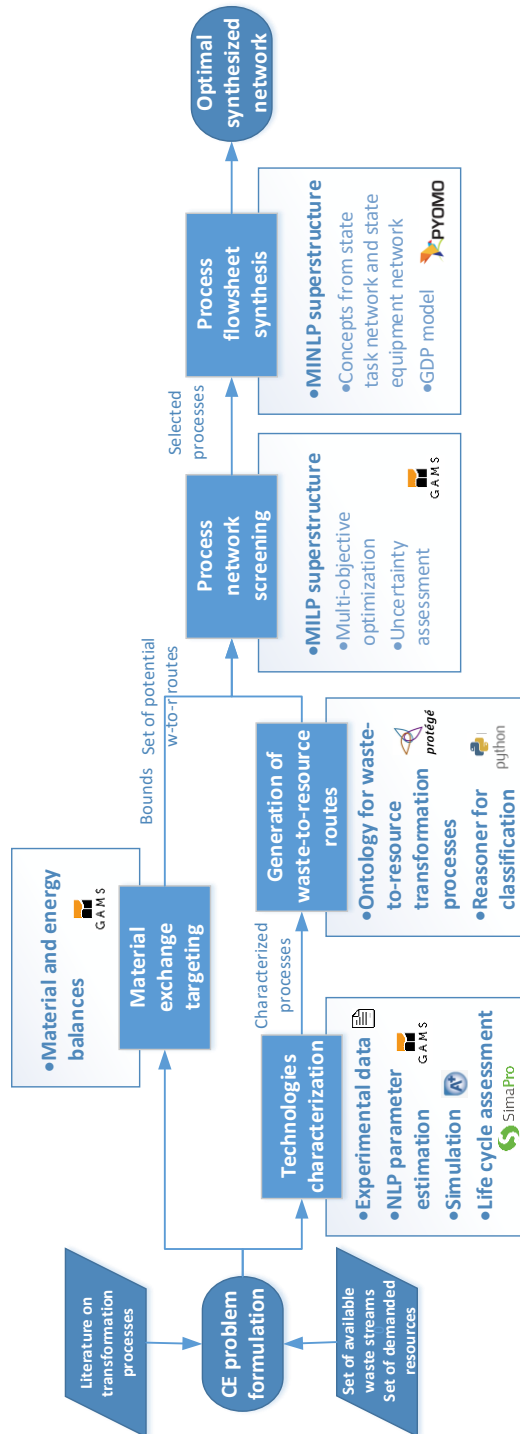

Figure 4.1. Scheme of the framework.

4. Optimization framework

In parallel, data regarding waste sources and required raw materials can be used to target the potential exchange (Chapter 9) and generate bounds for the optimization models.

The optimization problem is tackled by decomposing it into the two hierarchical decision levels involved: the network optimization at the strategic level (Chapters 10) and the optimal synthesis of processes at the tactical level (Chapter 11).

4.3. Industrial scope

The validation of the framework requires its application to an illustrative case study. Among many sectors in the Process Industry, the Thesis focuses on the plastic industry and the plastic waste, in particular, on those more complex cases requiring the chemical transformation of the waste. The decomposition of plastic waste into hydrocarbons (i.e. its chemical recycling) shows high potential as an alternative end-of-life for plastic as well as providing a source of hydrocarbons greener than fossil fuels. However, its industrial application has been hardly addressed in the literature because of the low Technology Readiness Level (TRL) of the revalorization processes presently available or under investigation. The following sections provide further insight on the problem of plastic waste and chemical recycling technologies.

4.3.1. The problem of plastic waste

Plastics represent the main product of the chemical industry on a mass basis. The annual production of plastic materials, which amounted 60 million tons in 2016 in Europe, is expected to increase in the short and mid-term (PlasticsEurope, 2018). Given their versatility, polyolefins are the most used plastics. Among them, polyethylene (PE) is at present the most widely demanded, representing 30% of the total production when considering all its varieties: high, medium, low and linear low-density polyethylene (PlasticsEurope, 2018). Currently, the main use of PE is packaging in the form of films, bottles or bags, which are very often single-use and, therefore, result in thousands of tons of plastic waste.

In 2016, 905 Mt of waste were generated in Europe (Eurostat - European Commission, 2016), the equivalent to 1.8 t per inhabitant. Despite only a 2% corresponds to the fraction of plastic waste, it adds up to 17 Mt of plastic waste that has is difficult to be managed.

According to statistics on waste management in Europe, during 2015 72% of plastic packaging was not recovered at all, 40% of which was sent to landfills while the other 32% was mismanaged (World Economic Forum; Ellen MacArthur Foundation; McKinsey & Company, 2016). This percentage of inadequately managed plastic causes severe environmental problems, being the deterioration of marine ecosystems and microplastics contamination some of the most controversial ones (Andrady, 2011; Hoornweg et al., 2013; Jambeck et al., 2015). Recent studies have shown that the problems related to plastic-waste accumulation are worsening dramatically, and that the main polymers responsible for this accumulation are by far PE and polypropylene (PP), the two most common polyolefins (Lebreton et al., 2018).

4.3.2. End-of-life alternatives for plastic waste

The recycling of PE and PP is not an easy task, as they degrade during melting. Certainly, they can be reused for lower-value applications, such as carpets, clothing or building materials, but their use to produce new added-value packaging items remains challenging. Another end-of-life alternative for these plastics is energy valorization by means of incineration, which is not an option closing the material loop. Furthermore, this strategy has also drawbacks, as valuable materials are lost in the form of CO₂, which raises concerns about its benefits (Lewtas, 2007). Hence, upcycling polymers into quality plastics again is sought as the way forward (Lacy et al., 2019). The treatment of waste polymers calls for adequate technologies that, in the case of PE, are at a very early development stage and show low TRL. The PE case perfectly fits the need of chemical transformation processes in which this thesis focuses.

Part II: Study of the potential benefits of circular economy in the chemical industry

Methodology for the characterization of waste-to-resource technologies

5.1. Introduction

A methodical procedure to characterize technologies is required to have comparable information despite having data from diverse sources and scales. This is particularly important in the case of technologies still under development (e.g. chemical recycling technologies), as lab results should be upscaled to test their industrial application. This chapter introduces the steps required to obtain reliable process data from experimental results.

5.2. Parameter estimation

Experimental data available in the literature is often in the form of outlet mass composition. Kinetic data on the degradation of waste can be found, but there is a lack of information on the mechanisms towards the decomposition into different products (e.g. the pyrolysis of polyethylene, (Al-Salem and Lettieri, 2010; Gao et al., 2003; Gascoin et al., 2012; Westerhout et al., 1997)). Thus, a first parameter estimation (Eqs. (5.1-5.4)) is needed to adjust this data to more functional stoichiometric coefficients. Quadratic error (Eq. (5.1)) is used to convert experimental mass fractions (w_i^{exp}) to stoichiometric coefficients (ν_i).

5. Methodology for the characterization of waste-to-resource technologies

$$\min Z = \sum_i (w_i^{exp} - w_i^{calc})^2 \quad (5.1)$$

$$\text{s. t. } n_i^f = n_i^o - \frac{\nu_i}{\nu_B} \cdot X_B \cdot n_{PE}^o \quad (5.2)$$

$$m_i^f = n_i^f \cdot MW_i \quad (5.3)$$

$$w_i^{calc} = \frac{m_i^f}{\sum_i m_i^f} \quad (5.4)$$

where:

- i = component
- w_i^{exp} = experimental mass fraction of component i in the outlet
- w_i^{calc} = calculated mass fraction of component i in the outlet
- n_i^o = calculated molar flow of component i in the inlet
- n_i^f = calculated molar flow of component i in the outlet
- X_B = conversion of base component
- ν_i = stoichiometric coefficient of component i

5.3. Simulation

Once the experimental results have been approximated to a chemical reaction, the process can be simulated according to operation conditions also available in the literature. Unknown conditions and process configurations can be estimated according to standard heuristics and other design procedures. Some of the hypothesis and decisions that have to be made include:

- The product composition will remain as in the experimental results.
- In the case of having a mixed stream as the outlet of the reactor, the separation process has to be assessed. First decisions involve the desired purity in final products (i.e. the amount of streams in which it is going to be separated according to fractions of components). For example, it may be considered not profitable to recover components present under a 5%. Then, the separation sequence has to be decided. In the most common cases, it will consist of a series of distillation columns according to some standard heuristics (e.g. direct distillation).
- The selection of energy sources has to be consistent among all the processes that will be compared (i.e. fossil fuels cannot be compared

to renewable sources. Equal levels of energy integration should also be applied.

5.4. Economic assessment

The aim of this economic assessment is to quantify the total annualized cost (TAC) of the waste-to-resource processes, which will be later employed to characterize its economic performance in the context of the whole life cycle of the LDPE (i.e. the corresponding input-output black-box model).

- *Total annualized cost*

To quantify the total annualized cost (TAC) of the waste-to-resource processes, the procedure proposed by Towler and Sinnott (2013) is followed, where the TAC is obtained by adding up an annualized capital cost (ACC) with the yearly fixed and operation costs (FC and VC) as is shown in Eq. (5.5).

$$TAC = ACC + FC + VC \quad (5.5)$$

To compute the ACC, the individual capital cost for each equipment (C_e) needs to be calculated. This is done using the correlation in Eq. (5.6), where a , b and n are equipment cost parameters and S denotes the size factor. Total capital cost is calculated in Eq. (5.7) by adding up the costs for all equipment units i , where f_i represents the installation factor.

$$C_e = a + b \cdot S^n \quad (5.6)$$

$$TCC = \sum_i C_{e_i} \cdot f_i \quad (5.7)$$

The total capital cost is annualized to obtain the ACC by considering 330 operational days per year, and a 10 years linear depreciation scheme, with a fixed interest rate of 15%. All the costs are extrapolated to 2019 using the Chemical Engineering Process Cost Index (CEPCI).

The annual fixed operating costs (FC) include labor costs (LBC), maintenance costs (MC), land cost (LNC), taxes and insurance costs (TIC), as well as general plants overheads (GOC), as follows:

$$FC = LBC + MC + LNC + TIC + GOC \quad (5.8)$$

Labor costs (LBC) consider both operation and supervision (LCO and LCS, respectively) as well as salary overheads (DSO).

5. Methodology for the characterization of waste-to-resource technologies

$$LBC = LCO + LCS + DSO \quad (5.9)$$

Maintenance (MC) and land costs (LNC) are given by the total equipment cost, which includes the main process (MPEC) and the heat exchanger network (HENEC), as illustrated in Eqs. (5.10,5.11). Taxes and insurance costs (TIC) were estimated from the total capital costs (Eq. (5.12)).

$$MC = 0.03 \cdot HENEC \quad (5.10)$$

$$LNC = 0.01 \cdot (MPEC + HENEC) \quad (5.11)$$

$$TIC = 0.015 \cdot TCC \quad (5.12)$$

The general overheads cost (GOC) is obtained as a percentage of labor and maintenance costs:

$$GOC = 0.65 \cdot (LBC + MC) \quad (5.13)$$

Finally, the annual variable operating cost (VC) is calculated in Eq. (5.14) as the summation of the cost on raw materials (CRM) and the utilities of the heat exchanger network (CWMW).

$$VC = CRM + CUHEN + CWMW \quad (5.14)$$

In the case of waste-to-resource technologies, the cost of the main raw material (waste) can be a key negotiation parameter when determining operating profit ranging from positive to negative values.

- *Revenues*

To complement the cost analysis, the revenues from selling products and byproducts are calculated according market prices.

5.5. Life cycle assessment

The processes analyzed in this Thesis is evaluated through Life Cycle Assessment (LCA). The guidelines to perform it are described in the standard ISO 14040:2006 (International Organization for Standardization, 2006), which divides an LCA in four phases: the definition of the goal and scope of the LCA, the life cycle inventory analysis (LCI), the life cycle impact assessment (LCIA), and the life cycle interpretation.

1. Goal and scope definition

First, the goal of the study is described and the boundaries of the system to analyze are stated (e.g. gate-to-gate, cradle-to-grave, etc.).

2. Life cycle inventory analysis (LCI)

The second step consists on the characterization of the inputs and outputs of the analyzed product or process, including the required amount of raw materials and energy, the emission of pollutants and the generated waste streams.

3. Life cycle impact assessment (LCIA)

In the life cycle impact assessment (LCIA) step, the total environmental impact factors are calculated according to the method of choice. Depending on the scope of the analysis and its final aim, results can be midpoint indicators (e.g. global warming) or endpoint indicators (e.g. human health).

4. Interpretation

Finally, results are analyzed and conclusions can be drawn.

5.6. Technology readiness levels

The maturity of a technology is assessed through its technology readiness level (TRL). TRLs were originally proposed by NASA but the version used in this Thesis is the one adopted by the European Commission (2014).

Table 5.1. Technology Readiness Levels (European Commission, 2014).

TRL	Description
1	Basic principles observed.
2	Technology concept formulated.
3	Experimental proof of concept.
4	Technology validated in lab.
5	Technology validated in relevant environment (industrially relevant environment in the case of key enabling technologies).

5. Methodology for the characterization of waste-to-resource technologies

6	Technology demonstrated in relevant environment (industrially relevant environment in the case of key enabling technologies).
7	System prototype demonstration in operational environment.
8	System complete and qualified.
9	Actual system proven in operational environment (competitive manufacturing in the case of key enabling technologies; or in space).

5.7. Echelons and supply chain assessment

The evaluation of the above criteria is valuable to analyze waste-to-resource technologies from different points of view. On the one hand, waste-to-resource processes can be compared against competing processes (Chapter 6). They can substitute waste treatment through traditional end-of-life technologies and displace business-as-usual technologies for added-value product generation. On the other hand, its integration on the supply chain (Chapter 7) can enhance or diminish this effect, due to the displacement of the cycles of materials.

Figure 5.1 illustrates the scheme for assessing whether or not the upcycling of materials would be economically and environmentally appealing. First, at the single echelon level, the process is characterized through the methods described above. Experimental data can be found in the literature and databases for conventional processes. After performing the process simulation to acquire data regarding material and energy balances and sizing parameters, a complete techno-economic and environmental assessment of the process is carried. Then, the process can be compared with the business-as-usual processes to generate products and other waste treatment technologies by adopting the same criteria (LCA and economic assessment). Afterwards, the effect on the whole supply chain is analyzed through the expansion of the system boundaries, where the waste-to-resource technology closes the cycle of materials. To do this, the same evaluation criteria are applied to the other processes that form the supply chain and then to the whole system.

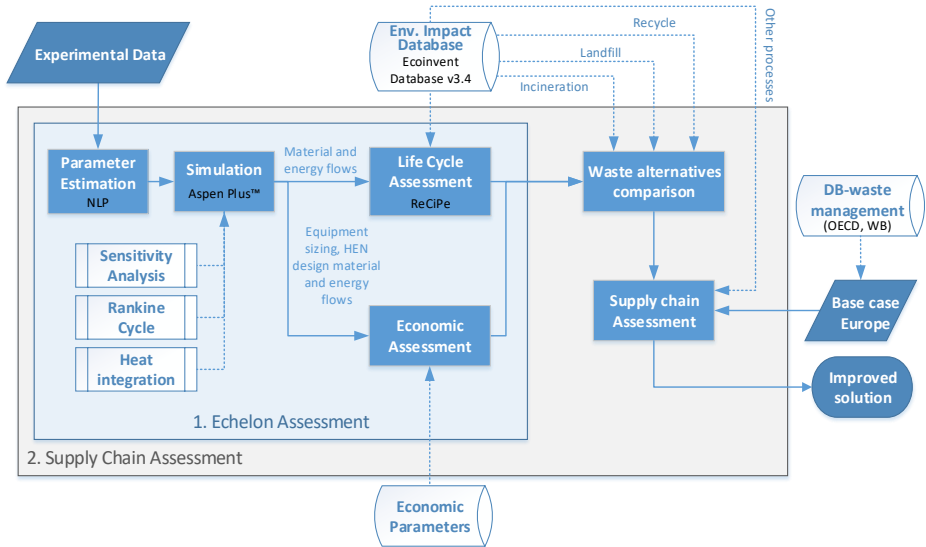

Figure 5.1. Scheme of the proposed methodology.

In the next chapters, in order to test the effectivity of the methodology, as well as to study the benefits of circular economy, it is applied to a case study: the supply chain of polyethylene (PE), with a focus on the introduction of pyrolysis for the recovery of ethylene.

Application on individual echelons

6.1. Introduction

The general problem of plastic waste management is discussed in Chapter 3. Polyethylene (PE) and polypropylene (PP) are the two main components of plastic waste (Lebreton et al., 2018). Their recycling is not an easy task, as they degrade during melting. As a result, they can mostly be reused for lower-value applications, such as carpets, clothing or building materials, while their use to produce new packaging items remains challenging. Another end-of-life alternative for these plastics is energy valorization by means of incineration. However, this strategy has also drawbacks, as valuable materials are lost in the form of CO₂, which raises concerns about its benefits (Lewtas, 2007). Hence, upcycling polymers into quality plastics again is sought as the way forward (Lacy et al., 2019). The treatment of waste polymers calls for adequate technologies that, in the case of PE, are at a very early development stage and show low Technology Readiness Levels (TRLs).

Different reviews on chemical technologies that would enable the transformation of PE into reusable monomer point towards pyrolysis as a promising alternative (Hong and Chen, 2017; Ragaert et al., 2017). Dong et al. (2019) analyzed the environmental performance of pyrolysis, gasification and incineration for the energy valorization of municipal solid waste, stating that pyrolysis and gasification are attractive alternatives worth researching. Furthermore, Fox and Stacey (2019) compared recently PE pyrolysis and gas-

6. Application on individual echelons

ification, finding that while pyrolysis is environmentally friendlier, gasification leads to higher revenues. Demetrious and Crossin (2019) evaluated landfill, incineration and gasification-pyrolysis as end-of-life alternatives for plastic waste, concluding that landfill is the most suitable option to reduce the environmental impact. These studies consider pyrolysis as a waste-to-energy technology, so environmental credits were only given to electricity generation. Benavides et al. (2017) and Faraca et al. (2019) both address the production of fuel oil via pyrolysis of plastic waste. To the author's knowledge, despite its potential to upcycle the building blocks of plastics, no previous work provided a detailed environmental and economic assessment of the use of pyrolysis to recover valuable chemicals.

At low temperatures, pyrolysis leads to oils and waxes, while at higher temperatures, the monomer is obtained in larger quantities. Several experimental studies, as those by Onwudili et al. (2009) and Mastral et al. (2002), revealed that PE conversion into olefins and other petrochemicals may reach 100% conversion at around 750 °C. However, even in this case, ethylene yields are still low (only 30% recovery), given that at this temperature more complex products are still dominant. Other studies reported similar results (Donaj et al., 2012; Park et al., 2019; Zeaiter, 2014), with a maximum ethylene recovery of 48% found at 1000 °C by Kannan et al. (2014). Furthermore, to the best of the author's knowledge, the highest scale at which experimental studies have been carried out is a 30 kg/h pilot plant (Kaminsky et al., 2004). Preliminary results generated at the lab scale as such cannot be directly used to envisage and assess the economic and environmental impact of new technologies and their integration into existing supply chains. To close materials loops in the chemical industry through circular economy strategies, the role of this technology needs to be projected, scaled and integrated.

Some attempts to model the pyrolysis of PE include the development of kinetic models (Gascoin et al., 2012) and process simulations (Vargas Santillán et al., 2016). However, a further technical, economic and environmental analysis is still required to assess the implications of industrializing this process. In order to provide a deeper assessment in terms of both economic and environmental criteria, this work assesses emerging technology for recovering ethylene from PE (via pyrolysis) following the principles of the circular economy. The analysis compares the PE pyrolysis against both, the business as usual (BAU) process for the production of ethylene, and two

conventional end-of-life alternatives for the treatment of waste PE. Overall, this chapter highlights the significant potential benefits that this technology can bring to the chemical industry, encouraging similar studies to promote the adoption of circular economy principles.

6.2. Materials and methods

The analysis is carried out by combining a palette of tools, namely process modeling, life cycle assessment (LCA) and economic evaluation as summarized in Figure 6.1. First, the process of waste PE pyrolysis is simulated in Aspen Plus at an industrial scale. This process model provides mass and energy flows and the sizes of the equipment units, which are then used in the economic and environmental calculations, the latter done in SimaPro using Ecoinvent v3.4 as database. Unitary costs and environmental impacts of ethylene obtained via waste PE pyrolysis and naphtha cracking are compared. Finally, a comparison of the environmental impact of treating 1 kg of waste PE through pyrolysis, landfilling and incineration is performed.

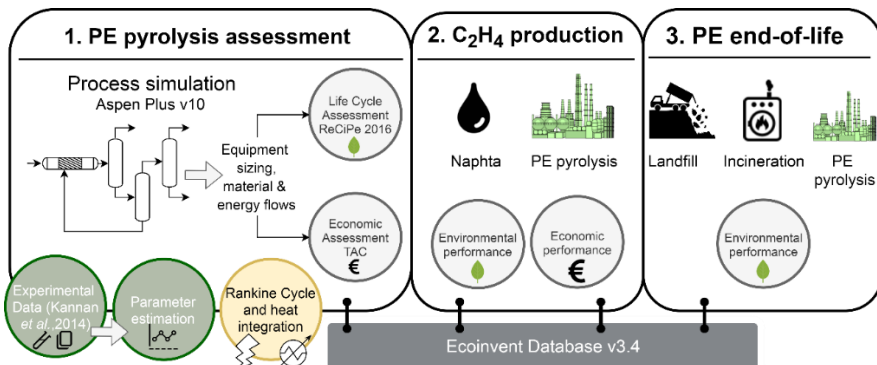

Figure 6.1. Methodology applied in the assessment.

6.3. Parameter estimation and simulation

Figure 6.2 depicts the process flowsheet for ethylene production from PE pyrolysis. The process starts by feeding 450 tons per day of purified waste PE (18,900 kg/h). This amount is equivalent to the PE waste generated daily by

6. Application on individual echelons

eight million people, which is the population of a big city such as London, or an average European region such as Catalonia in Spain.

The feed of PE enters a furnace operating at 1000°C and 1 bar, where the pyrolysis takes place. The furnace requires a total heat of 27.8 MW, which is provided by a mixture of hydrocarbons coming from one of the streams of the process, thereby avoiding the consumption of natural gas. The distribution of the products follows Eq.(6.1), which represents a global reaction whose stoichiometric coefficients were adjusted according to the data reported by Kannan et al. (2014):

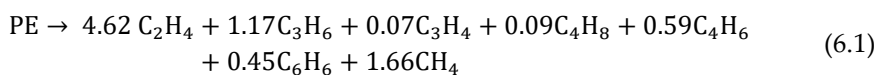

The gas leaving the reactor is sent to the evaporator of a steam Rankine cycle to generate electricity from the heat generated during the pyrolysis. The gas stream is cooled down to 60 °C in the evaporator. After the evaporator, the reactor outlet stream enters a series of three compressors before being sent to the distillation train. After each compression stage, the gas is cooled down to reduce the temperature and the energy consumption of the next compression stage. The gas stream enters the distillation train at 30 bar and 40°C.

The first column recovers 99% of methane from the hydrocarbons mixture with a purity of 99.5 wt%. This column has 25 trays and operates with a reflux ratio of 15.4. The bottoms of column T1 enter T2 after reducing the pressure to 25 bar in valve V1. In this column, 99.9% of ethylene is recovered at the top of the column with a purity of 99.5 wt%. The high recovery of ethylene aims to increase the purity of propylene to polymer-grade in the next separation. The column has 20 trays and operates with a reflux ratio of 2.3. The pressure of the bottoms stream leaving T2 is reduced to 10 bar and then fed to T3, which recovers 99% of propylene at the top with a purity of 99.5 wt%. The column has 30 stages and operates with a reflux ratio of 4.2. The final column T4 operates at atmospheric pressure and recovers 99% of benzene at the bottoms with a mass purity of 99.5 wt%. T4 has 12 stages and operates with a reflux ratio of 0.2. A mixture of propylene, propyne, 1-butene, 1,3-butadiene, and benzene is obtained at the top of the column. Some of these products

have market value; however, the separation process is complex and the revenues would probably fail to offset the costs of the separation. Instead, this stream is used to satisfy the entire fuel demand of the pyrolysis furnace.

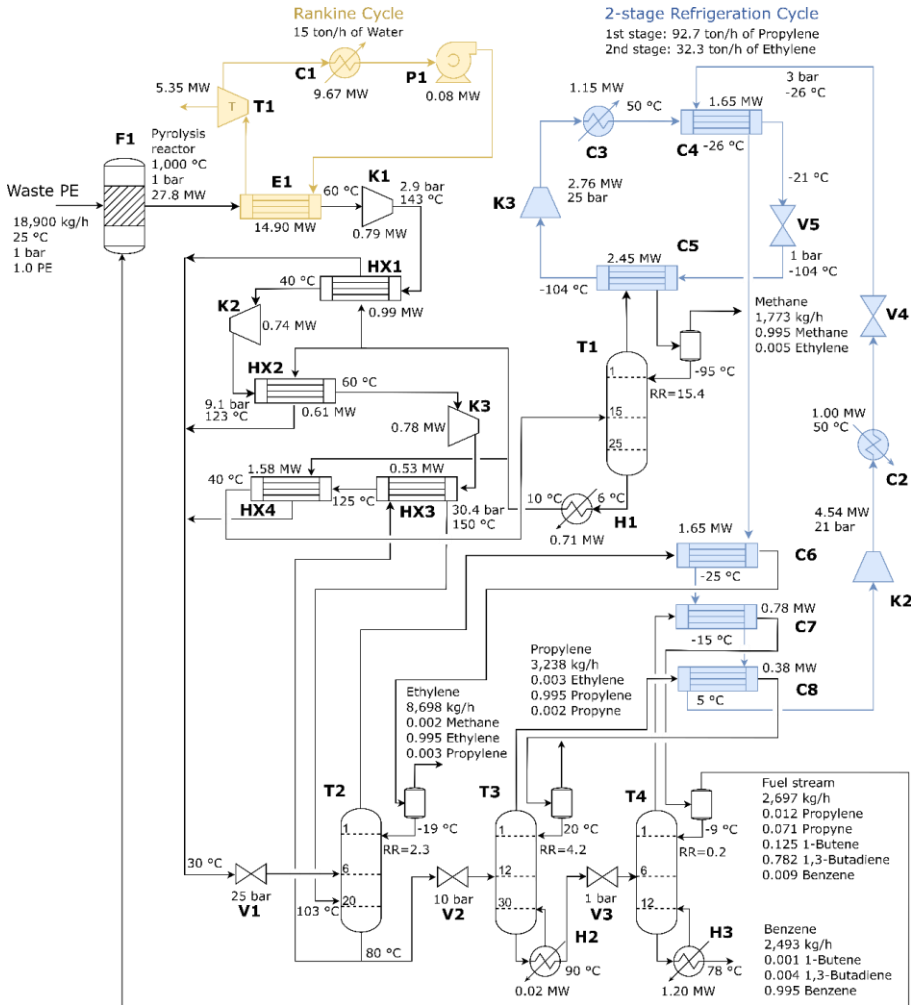

Figure 6.2. Flowsheet for the PE pyrolysis with heat recovery.

The process was simulated in Aspen Plus v10 using the POLYNRTL fluid package to model the thermodynamic properties of the components and their mixtures. This method implements the Van Krevelen’s group contribution method to estimate the properties of the polymer (Krevelen and Nijenhuis,

6. Application on individual echelons

2009). The method is suitable for both the modelling of the polymer pyrolysis and the subsequent separation of the resulting hydrocarbons.

Heat integration was carried out using Aspen Energy Analyzer v10, which suggests to use the heat generated by compressors K1 to K3 to heat the reboilers of columns T1 and T2. The cooling requirements in the condensers of the four columns cannot be met with cooling water. To satisfy this service, a two-stage refrigeration cycle reported by Luyben (2017) was implemented, as depicted in Figure 6.2. The first stage of the cycle uses a flowrate of 92.7 ton/h of propylene in a closed loop. In this stage, compressor K2 operates at 21 bar and discharges the gas at 112°C. Propylene is then condensed at 50°C and depressurized to 3 bar in valve V4, reaching -26°C. At this point, the stream is used to reduce the temperature of the fluid in the second stage of the cycle, and the condensers of columns T2 (-19°C), T4 (-9°C), and T3 (19°C), respectively. The second stage of the refrigeration cycle uses 32.3 ton/h of ethylene in a closed loop, which is pressurized to 25 bar in K3, cooled down to 50°C in C3 and then cooled down further with the propylene of the first stage to -21°C in C4. After reducing the pressure to 1 bar in V5, ethylene reaches -104 °C, which is enough to satisfy the required temperature of -94°C in the condenser of T1. The refrigerants of both sections have a lifetime of eight years.

6.4. Economic assessment

The economic performance was quantified using the total annualized cost per kg of recovered ethylene (TAC/kg of C₂H₄). The TAC is calculated as the sum of the fixed costs of operation (FC), variable costs (VC), and annual capital charge (ACC) following the procedure reported by Towler and Sinnott (2013):

$$\text{TAC} = \text{FC} + \text{VC} + \text{ACC} \quad (6.2)$$

The annual fixed operating costs (FC) include labor, maintenance, land, taxes and insurance costs, as well as general plants overheads, all of which are calculated as a function of the capital investment and production capacity. The variable operating costs (VC) include the cost of raw materials and utilities consumption minus the revenues from byproducts. Capital costs were calculated using the correlations reported by Towler and Sinnott (2013)

considering the corresponding installation factors. The plant is located in Europe, meaning that a regional factor of 1.1 was considered in the capital costs estimation. Capital costs were annualized considering 330 operational days per year, and a 10 years linear depreciation scheme with a fixed interest rate of 15%. All the costs were extrapolated to 2019 using the Chemical Engineering Process Cost Index (CEPCI). In addition, costs retrieved in USD were converted to Euros (€) using a factor of 1.13 USD/€. The costs of raw materials, utilities, and products used in the analysis are reported in Table 6.2.

6.5. Environmental assessment

The environmental performance was quantified applying life cycle assessment (LCA) in accordance to the ISO 14040:2006 standards (International Organization for Standardization, 2006).

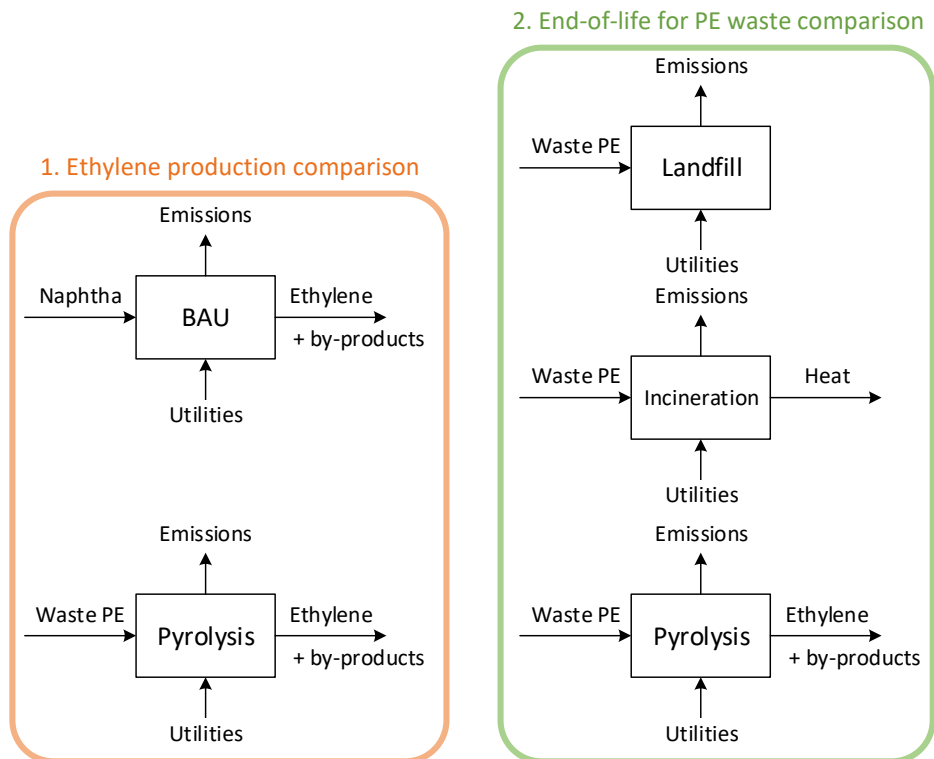

Figure 6.3. Diagram of the processes considered in the two parts of the assessment.

6. Application on individual echelons

The goal of the LCA is twofold as represented in Figure 6.3. First, to assess the environmental impact of the ethylene produced *via* pyrolysis of PE, comparing it against the naphtha-based business as usual (BAU) process in Europe. For the sake of comparability with the business as usual for the production of ethylene, the results from the process simulation are escalated to a functional unit of 1 kg of ethylene produced, to which all the calculations will be referred. Second, the analysis compares the environmental impact of processing 1 kg of waste PE against two conventional end-of-life stages of PE: incineration and landfill. For the latter case, the functional unit was set as the treatment of 1 kg of waste PE. In the first case, a cradle-to-gate scope is applied, considering the burdens embodied in raw materials and energy inputs, while disregarding the end-of-life phase of the monomer according to the flowsheet presented in Figure 6.2. In the second case, pyrolysis is considered as an end-of-life alternative for the treatment of PE waste and compare it with its landfill and incineration. The plant is located in Europe and the analysis considers environmental credits associated with byproducts for avoiding their production *via* conventional routes (avoided burden approach).

Table 6.1. Costs and environmental entries for the inputs in the process.

Concept	Cost (€/unit)	Process taken from Ecoinvent v3.4
Products		
Methane (kg)	0.334	* Market for natural gas, high pressure, Europe without Switzerland.
Ethylene (kg)	1.075	**Ethylene production, average, Europe without Switzerland.
Propylene (kg)	0.875	*Production of propylene, RER
Benzene (kg)	0.994	*Production of benzene, RER
*Products considered as avoided products in the LCA assessment.		
** Process for the BAU production method of ethylene		
Raw materials		
Polyethylene (kg)	0.315	Treatment of waste polyethylene, for recycling, unsorted, sorting, RER
Utilities		

Electricity (kWh)	0.110	Market group for electricity, high voltage, RER
Cooling water (kW)	$4.38 \cdot 10^{-3}$	Market group for electricity, high voltage, RER. Cooling duty is replaced by the electricity required to pump water within the cooling cycle (9.5 kWh/MWh of cooling water).
Low pressure steam (1,000 kg)	7.820	Market for heat, from steam, in chemical industry, RER
Fuel (kW)	-	No cost or impact considered as stream from top of T4 is used as fuel, avoiding the consumption of any additional fuel.
Equipment		
Steel (kg)	-	Steel production, converter, chromium steel 18/8, RER. Compressors and turbines are not considered. Amount calculated considering 25 years of lifetime.
Furnace (1 piece)	-	Industrial furnace, natural gas, RER. Amount calculated considering 25 years of lifetime.
Polyethylene end-life treatment		
Municipal incineration (kg)	-	Treatment of waste polyethylene, municipal incineration Europe without Switzerland
Landfill (kg)	-	Treatment of waste polyethylene, sanitary landfill Europe without Switzerland
Heat (MJ) (credit for incineration)	-	Market for heat, district or industrial, natural gas, Europe without Switzerland

The inventory within the boundaries of the system, i.e., foreground system, was obtained from the material and energy balances of the process simulation. The entries beyond these boundaries, i.e., background system, were retrieved from the Ecoinvent database v3.4 (Wernet et al., 2016), accessed via SimaPro (Goedkoop et al., 2016). When available, datasets for the European

6. Application on individual echelons

electricity mix were gathered (“RER” or “Europe without Switzerland” geographical location shortcut in Ecoinvent). In the case of manufacture processes, market datasets were selected to consider production mixes from different conventional processes. Table 6.1 presents the entries considered in the assessment.

The feed of waste PE is assigned the cost and impact of sorting, given that after common industrial or urban use, waste PE may be mixed with other plastic, metallic or organic materials. The impact of cooling water is calculated as the electricity required to pump the water that satisfies the heat demand. As for the fuel, given that a process stream is used, the only impact considered is related to the direct emissions of CO₂ during the combustion. Gonzalez-Garay and Guillen-Gosalbez (2018) found CO₂ emissions to be the most critical emissions in this combustion step, as other emissions are low due to the efficient combustion processes considered. The environmental flows associated to the equipment units were estimated from the corresponding steel requirements for the construction of distillation columns, heat exchangers and industrial furnace. The impact of the equipment was amortized using a lifetime of 25 years.

When comparing the different end-of-life processes of waste polyethylene, the burdens of the use and collection stages are neglected. This is due to lack of information and potential high variability of the results according to the different waste management policies. However, this level of detail is not required for comparative LCAs, where identical processes and life-cycle stages can be excluded, given that only differences between the compared systems are relevant for discriminating between them in environmental terms (European Commission - Joint Research Centre, 2010). In the analysis, landfilling PE waste does not produce any valuable product, so no credits are assigned to this end-of-life alternative. As for incineration, credits are assigned for the heat produced to reflect the burden avoided by replacing the conventional heat generation process. High-pressure steam is generated by burning LDPE waste with a heating value of 42.83 MJ/ kg (Phyllis2 database for biomass and waste, 2019) in a boiler with 60% efficiency (Grosso et al., 2010).

6.6. Results

6.6.1. Economic assessment

The net flows per kg of ethylene produced by the process are reported in Table 6.2, while the sizing parameters of the equipment units are reported in Table 6.3.

Table 6.2. Net flows of the process per kg of C₂H₄ produced (no allocation considered).

Concept	Amount per kg/h of C₂H₄
Products	
Methane (kg/h)	0.204
Propylene (kg/h)	0.378
Benzene (kg/h)	0.287
Raw materials	
Polyethylene (kg/h)	2.17
Utilities	
Net electricity consumption (kW)	0.454
Electricity main process (kW)	0.231
Electricity refrigeration cycle (kW)	0.839
Electricity generated Rankine cycle (kW)	-0.615
Cooling water (kW)	2.447
Low pressure steam (kW)	0.222
Fuel (kW)	3.201
Water (kg/h) (steam Rankine cycle)	$2.69 \cdot 10^{-5}$
Ethylene (kg/h) (refrigeration cycle)	$1.64 \cdot 10^{-4}$
Propylene (kg/h) (refrigeration cycle)	$5.80 \cdot 10^{-5}$
Equipment	
Steel (kg/h)	$9.63 \cdot 10^{-5}$
Direct emissions (fuel combustion)	
CO ₂ (kg/h)	0.986

6. Application on individual echelons

Table 6.3. Equipment operating conditions, sizing and installation cost of the process.

Equipment	Sizing parameter	Installed Cost (€)
Main process		
Furnace (F1)	27.8 MW Temperature: 1000°C Pressure: 1 bar	$3.55 \cdot 10^6$
Compressor K1	797 kW	$1.80 \cdot 10^6$
Compressor K2	743 kW	$1.74 \cdot 10^6$
Compressor K3	769 kW	$1.44 \cdot 10^6$
Column T1	25 stages Diameter: 1.676 m Mass shell: 5,304 kg Pressure: 30 bar Reflux ratio: 15.4	$5.77 \cdot 10^5$
Column T2	20 stages Diameter: 1.372 m Mass shell: 3,543 kg Pressure: 25 bar Reflux ratio: 2.3	$4.31 \cdot 10^5$
Column T3	30 stages Diameter: 0.914 m Mass shell: 2,329 kg Pressure: 25 bar Reflux ratio: 4.2	$3.25 \cdot 10^5$
Column T4	12 stages Diameter: 0.762 m Mass shell: 885 kg Pressure: 1 bar Reflux ratio: 0.2	$1.85 \cdot 10^5$
Heat Exchanger Network	C5 (2.45 MW, 1,511 m ²)	$3.89 \cdot 10^4$
	C6 (1.65 MW, 1,599 m ²)	$4.12 \cdot 10^4$
	C7 (0.78 MW, 219 m ²)	$5.69 \cdot 10^3$
	C8 (0.38 MW, 169 m ²)	$4.15 \cdot 10^3$
	H1 (0.71 MW, 31 m ²)	$1.11 \cdot 10^3$
	H2 (0.02 MW, 4 m ²)	$3.69 \cdot 10^3$
	H3 (1.20 MW, 119 m ²)	$2.78 \cdot 10^3$
	HX1 (0.99 MW, 314 m ²)	$8.09 \cdot 10^3$
	HX2 (0.61 MW, 76 m ²)	$2.01 \cdot 10^3$
	HX3 (0.53MW, 76 m ²)	$2.01 \cdot 10^3$

	HX4 (1.58 MW, 179 m ²)	4.15·10 ³
<i>Total main process</i>		1.47·10 ⁷
Rankine cycle		
Turbine T1	5,352 kW	5.09·10 ⁶
Pump P1	84 kW	1.25·10 ⁵
Condenser C1	315 m ² (9.7 MW) U=1,500 W/m ² C	3.10·10 ⁵
Evaporator E1	103 m ² (14.9 MW) U=1,500 W/m ² C	1.59·10 ⁵
<i>Total Rankine Cycle</i>		5.69·10 ⁶
Refrigeration cycle		
Compressor K2	4,537 kW	4.75·10 ⁶
Compressor K3	2,761 kW	3.49·10 ⁶
Condenser C2	224 m ² (10.5 MW) U=900 W/m ² C	2.42·10 ⁵
Cooler C3	107 m ² (1.15 MW) U=200 W/m ² C	1.62·10 ⁵
Condenser C4	997 m ² (3.9 MW) U=150 W/m ² C	9.18·10 ⁵
<i>Total refrigeration cycle</i>		9.56·10 ⁶
Total		2.99·10⁷

Equipment sizing was carried out in 'Aspen Plus v10' and 'Aspen Energy Analyzer v10', while capital costs were calculated as described in section 6.4. While the ultimate aim of the simulation is to characterize a functional unit of 1 kg of ethylene, simulating such a small amount would inevitably lead to less accurate results ignoring the effect of economies of scales. To overcome this and obtain more accurate values for yields and utilities consumption, some simulations were performed considering an inlet of waste PE of 18900 kg/h before normalizing them for a functional unit of 1 kg of ethylene. The breakdown of the capital costs is shown in Figure 6.4.

The treatment of waste PE is a highly energy-intensive process due to the fuel, cooling water and electricity requirements in Table 6.2. A total of 2.17 kg of PE are required to produce 1 kg of ethylene, 0.2 kg of methane, 0.4 kg of propylene, and 0.3 kg of benzene. A great advantage of the process is the reduction of electricity consumption by 60% through the incorporation of a

6. Application on individual echelons

steam Rankine cycle, which allows the generation of 5.3 MW of electricity (efficiency of 36%). Similarly, the process avoids the use of natural gas or any other fuel in the furnace by using the top of T4 as fuel, which mainly contains C3's and C4's. This strategy, however, increases the CO₂ emissions with respect to natural gas by 31.7%, resulting in direct emissions of 0.986 kg of CO₂ per kg of ethylene produced. Heat integration also allowed a reduction of heating and cooling demand by 66% and 36%, respectively.

Figure 6.4 shows the main contributors to the capital cost of the process. The pyrolysis reactor contributes with 12%, the compressors of the main process represent 18%, and the heat exchanger network (HEN) represents 15%. The need for cryogenic temperatures, provided by the refrigeration cycle, contributes significantly to the total capital cost of the process (32%). The cost per kJ of the cycle is 0.44 €, considering both the annualized capital cost and energy consumption. Luyben(Luyben, 2017) reported a value of 0.48 € (0.54 USD) per kJ generated in the second stage of the cycle. The difference in cost comes from the additional provision of cooling utilities in the first stage of the cycle together with the use of different cost correlations and depreciation scheme. Finally, the Rankine cycle represents 19% of the capital costs with an annualized capital cost of $1.14 \cdot 10^6$ €/yr. The electricity generated by the cycle saves $4.71 \cdot 10^6$ € per year, which is four times larger than the annualized cost of the cycle, clearly offsetting the investment.

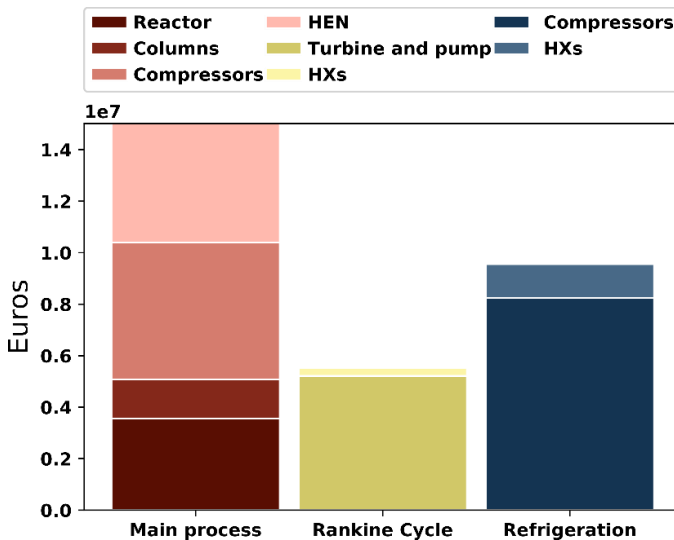

Figure 6.4. Capital costs breakdown.

6.6.1.1. Production of ethylene

Figure 6.5 shows the total cost of production per kg of C_2H_4 . Following the procedure described by Towler and Sinnott (2013), the revenues obtained from the byproducts are subtracted from the variable costs of production, resulting in a total cost of 0.386 €/kg of C_2H_4 . The main contributor to the costs of production is waste PE, with a share of 64% (0.684 €/kg of C_2H_4), which comes from the cost of sorting the waste PE. It is worth noting that this contribution could increase if additional treatment of waste PE is required. The second largest contributor are the capital and fixed costs, with a share of 30% (0.239 and 0.084 €/kg of C_2H_4 , respectively), while utilities represent the remaining 6% (0.062 €/kg of C_2H_4). The sales of byproducts represent 64% of the total costs of production, which is the same contribution as the waste PE. As a result, the TAC/kg of C_2H_4 is mainly given by the cost of utilities and annualized capital costs. Among the byproducts, methane contributes with 0.068 €/kg of C_2H_4 , propylene with 0.331 €/kg of C_2H_4 , and benzene with 0.285 €/kg of C_2H_4 .

As observed from Figure 6.5, the TAC/kg of C_2H_4 can be reduced by half compared to the 0.835 €/kg of C_2H_4 reported by Spallina et al. (2017) for the BAU process. These results clearly show a high economic potential. However, full kinetic data would be necessary to properly identify, model, and optimize the distribution of the products obtained in the reactor. Similarly, any pre-treatment process required should be discussed and integrated in the model.

In a different configuration, methane could be burned to generate steam used in a Rankine cycle. Considering a boiler and steam Rankine cycle efficiencies of 75% and 30%, respectively, this configuration would generate 0.643 kW/kg of C_2H_4 . As a result, the process would be self-sufficient in terms of electricity and would still generate a surplus of 0.189 kW/kg of C_2H_4 . This electricity surplus represents 0.021 €/kg of C_2H_4 , which almost offsets the capital costs of the steam Rankine cycle (0.023 €/kg of C_2H_4). However, at the considered market conditions, it is still more profitable to sell the methane and pay for the electricity, which leads to a profit of 0.018 €/kg of C_2H_4 , in contrast to the self-sufficient configuration, which provides no profit.

6. Application on individual echelons

Under the market assumptions considered in this assessment, the introduction of waste PE pyrolysis in the ethylene market seems feasible. However, it is not expected that this technology will fully substitute ethylene production from naphtha, and therefore, the total production cost of 0.386 €/kg of C₂H₄ only represents a lower bound.

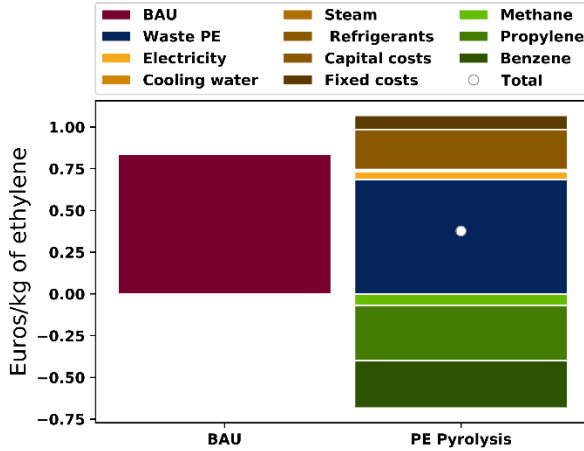

Figure 6.5. Total cost per kg of ethylene.

6.6.1.2. Treatment of waste PE

Figure 6.6 depicts the total cost of treating waste polyethylene at the different end-of-life alternatives: landfill, incineration or pyrolysis. The functional unit for this case is the treatment of 1 kg of waste PE. Here, credits of ethylene are also accounted for, as it is a byproduct from the process.

In terms of cost, landfill presents the lowest value with 0.10 €/kg of waste PE. However, when credits for heat or byproducts production are considered, it becomes the most expensive end-of-life alternative because of the lack of energy or materials recovery. Incineration has a total cost of 0.08 €/kg after pondering its 0.13 €/kg cost and 0.05 €/kg of credits for heat production. In contrast, pyrolysis stands as the only economically efficient alternative: a treatment cost of 0.49 €/kg is compensated with a profit of 0.81 €/kg. Ethylene leads to a 61% of the revenues. Methane, propylene and benzene have contributions of 4%, 19% and 16%, respectively.

These results present pyrolysis as a very competitive alternative to treat waste polyethylene. Further profit could be obtained if sorting costs are reduced.

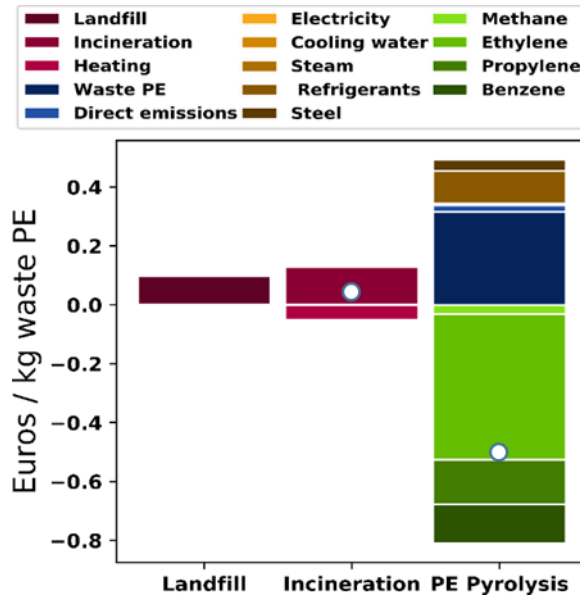

Figure 6.6. Total cost per kg of waste PE.

6.6.2. Environmental assessment

6.6.2.1. Production of ethylene

Figure 6.7 shows the environmental impact of 1 kg of ethylene for both, the BAU and PE pyrolysis processes. It can be observed that the categories of human health and ecosystems quality behave similarly. In both cases, the emissions of CO₂ from the fuel combustion (direct emissions) show the largest contribution to the impact, with shares of 47% in human health and 58% in ecosystems quality ($9.15 \cdot 10^{-7}$ DALYs/kg and $2.76 \cdot 10^{-9}$ Species-yr/kg, respectively). The high-energy requirements of the process lead to contributions of 26% in human health and 24% in ecosystems quality ($5.16 \cdot 10^{-7}$ DALYs/kg and $1.16 \cdot 10^{-9}$ Species-yr/kg, respectively). Waste PE, the raw material carrying the impact embodied in sorting, contributes with 27% of the impact in human

6. Application on individual echelons

health and 18% in ecosystems quality ($5.26 \cdot 10^{-7}$ DALYs/kg and $8.70 \cdot 10^{-10}$ Species-yr/kg, respectively). In the category of resources scarcity, the impact related to waste PE, utilities, emissions and equipment is negligible (0.016 USD/kg of ethylene). As mentioned in section 6.5, the byproducts are considered as avoided products, so credits are taken from their production according to the processes described in Table 6.1. From Figure 6.7, it can be observed that these credits almost offset the impact of the process activities in the categories of human health and ecosystems quality. The net impact value of the process is $2.67 \cdot 10^{-7}$ DALYs/kg in human health, $5.57 \cdot 10^{-10}$ Species-yr/kg in ecosystems quality, and $-3.85 \cdot 10^{-1}$ USD/kg in resources scarcity. In the case of human health, methane reduces the impact by $4.30 \cdot 10^{-10}$ DALYs/kg, propylene by $8.31 \cdot 10^{-7}$ DALYs/kg, and benzene by $8.60 \cdot 10^{-7}$ DALYs/kg. In the ecosystems quality category, methane reduces the impact by $1.03 \cdot 10^{-12}$ Species-yr/kg, propylene by $2.10 \cdot 10^{-9}$ Species-yr/kg, and benzene by $2.13 \cdot 10^{-9}$ Species-yr/kg. The impact in the resources scarcity category is reduced in $2.47 \cdot 10^{-4}$ USD/kg by methane, $2.31 \cdot 10^{-1}$ USD/kg by propylene, and $1.70 \cdot 10^{-1}$ USD/kg by benzene.

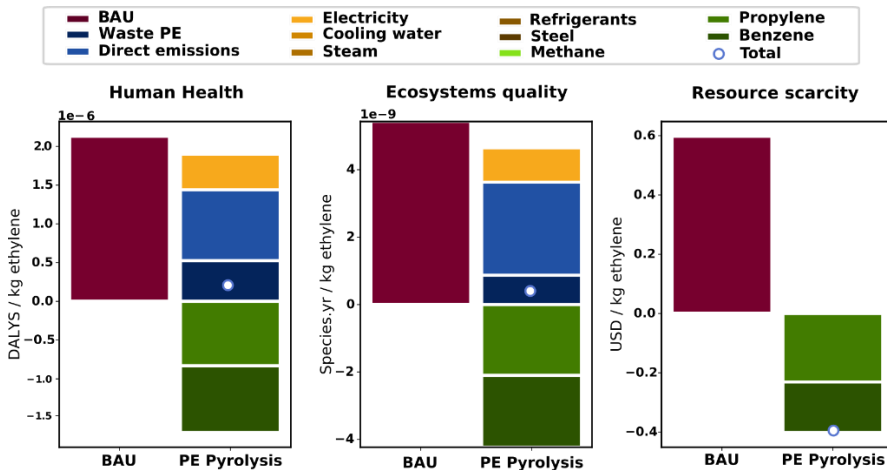

Figure 6.7. Impacts of polyethylene pyrolysis with respect to producing ethylene from naphtha.

The use of a different allocation method could vary the results. However, even when the full impact of the pyrolysis of PE is considered, that is, no credits are assumed, the value in all the categories is still lower than the BAU.

Regardless of the allocation method used, this value would be further reduced when considering credits, clearly demonstrating the environmental benefits of the process in addition to the economic advantages discussed in the previous section.

6.6.2.2. Treatment of waste PE

Figure 6.8 shows the comparison between the two most common end-of-life processes for waste PE with the pyrolysis process.

In the category of human health, the pyrolysis of PE represents the best option with a negative impact of $-0.86 \cdot 10^{-6}$ DALYS/kg of waste PE. The negative value is given by the credits of byproducts. Incineration represents the second best alternative, with a net impact value of $0.64 \cdot 10^{-6}$ DALYS/kg of waste PE considering credits for the heat cogenerated. Landfill has the largest impact, with a value of $0.80 \cdot 10^{-6}$ DALYS/kg of waste PE. Pyrolysis also represents the best alternative in the category of ecosystems quality, with a net value of $-0.23 \cdot 10^{-8}$ Species·yr /kg of waste PE, followed by landfill and incineration ($0.06 \cdot 10^{-8}$ and $0.14 \cdot 10^{-8}$ Species·yr /kg of waste PE, respectively). Finally, it can be observed that the contribution to the category of resources scarcity is significantly low in all the end-of-life alternatives, given that no mineral or fossil resources are being consumed. PE pyrolysis has the lowest impact with a value of -0.45 USD/kg of waste PE, followed by incineration with -0.34 USD/kg of waste PE, and landfill with $0.02 \cdot 10^{-1}$ USD/kg of waste PE. Given the revalorisation of waste PE in the pyrolysis, it is evident that the process would render the best performance for its end-of-life stage. However, it must be considered that the byproducts will still generate an impact in downstream processes and, consequently, care should be placed in their management to ensure a sustainable performance in the entire cycle.

6. Application on individual echelons

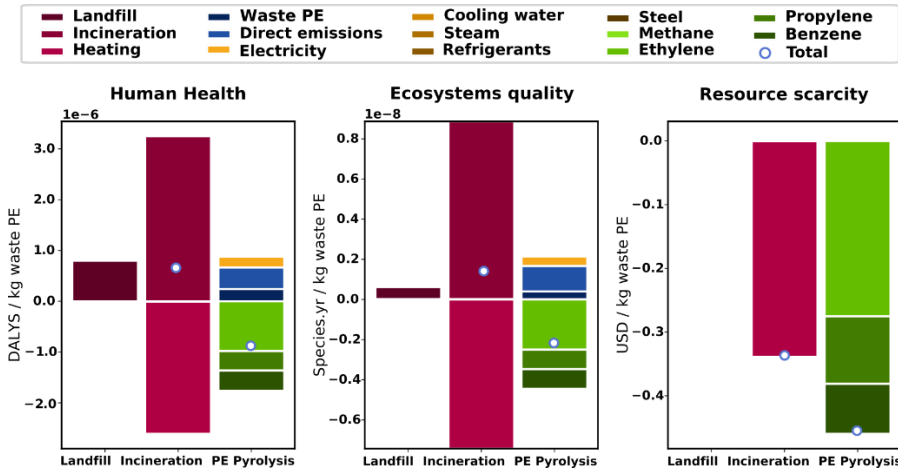

Figure 6.8. Endpoint environmental impact of end-of-life alternatives for waste PE.

With the aim to analyze the main contributors to the endpoint impacts, Figure 6.9 shows the result for the midpoint indicators. These include climate change (CC, in kg CO₂/kg waste PE), terrestrial acidification (TA, in kg SO₂/kg waste PE), water consumption (WC, in m³ of water/kg waste PE), freshwater eutrophication (FE, in kg P to fresh water/ kg waste PE), marine ecotoxicity (ME, in kg 1,4-dichlorobenzene/kg waste PE) and fossil resources scarcity (FRE, in USD2013/kg waste PE). Climate change behaves similarly to human health in terms of drivers. This is not surprising, giving that climate change is in turn the main driver of human health, contributing 36% to the net impact on the latter category. Incineration scores the highest in CC, leading to both high environmental burdens and benefits. This process entails 3.02 kg of CO₂ direct emissions, while 2.44 kg are avoided through the production of heat from the European mix, leading to net emissions of 0.574 net kg of CO₂ per kg of waste PE treated. Conversely, while the environmental burden of PE pyrolysis is driven by its direct emissions, a net environmental benefit of avoided 0.560 kg of CO₂ is observed when giving credits to the recovered products. Main contributors to the impact on ecosystems are TA, FE and ME. Incineration and pyrolysis entail avoided SO₂ emissions of $1.14 \cdot 10^{-3}$ and $2.12 \cdot 10^{-3}$ kg, respectively. Pyrolysis significantly underperforms the other end-of-life alternatives in freshwater eutrophication due to the high electricity requirements in the separation process, while marine ecotoxicity is considerably lowered by the reutilization of materials. Together with fossil

fuel utilization, water consumption is an indicator of resources depletion. In this case, pyrolysis beats the other two through savings of 0.538 l of water consumption as it avoids the extraction of oil, naphtha production and its further processing into hydrocarbons.

The same results as Demetrious and Crossin (2019) are reached in terms of the low environmental impact of plastic waste landfill. However, having a process specifically designed to recover plastic monomers allows acknowledging the credits for material recovery. These findings are aligned to those of Dong et al.(Dong et al., 2019), where pyrolysis is perceived as a promising technology to manage mixed solid waste because of its high potential environmental benefits, leading to GHG net emissions of 0.15 kg CO₂-eq/kg mixed solid waste.

A different treatment of waste PE entails the production of fuels. In the analysis conducted by Benavides et al. (2017) for the production of naphtha, waste PE pyrolysis presented net GHG emissions of 0.31 kg CO₂-eq/kg of waste PE. In a different study, Faraca et al.(2019), who also assessed the production of fuel oil from waste polymers pyrolysis, reported emissions around 0.5 kg CO₂-eq/kg of waste PE. Despite a detailed process flowsheet was not reported in any of the previous cases, the results for the pyrolysis process are considered in agreement with the 0.56 kg CO₂-eq/kg of waste PE reported in this assessment. However, despite the similarity of the processes, the products distribution varies according to the operating conditions, which results in different net emissions of each system. In the analysis reported by Benavides *et al.*(Benavides et al., 2017), the system is given credits by the production of diesel, naphtha, char, and fuel gas, resulting in net emissions of -0.35 kg CO₂-eq/kg of waste PE. Faraca et al. (2019), reported crude oil and light gas as products of the system with net emissions of 0.40 kg CO₂-eq/kg of waste PE. In this case, the byproducts considered in the analysis have low emissions credits embedded, resulting in positive net emissions of the system. As observed from Fig. 8, the recovering of ethylene results in net emissions of -0.56 kg CO₂-eq/kg of waste PE.

6. Application on individual echelons

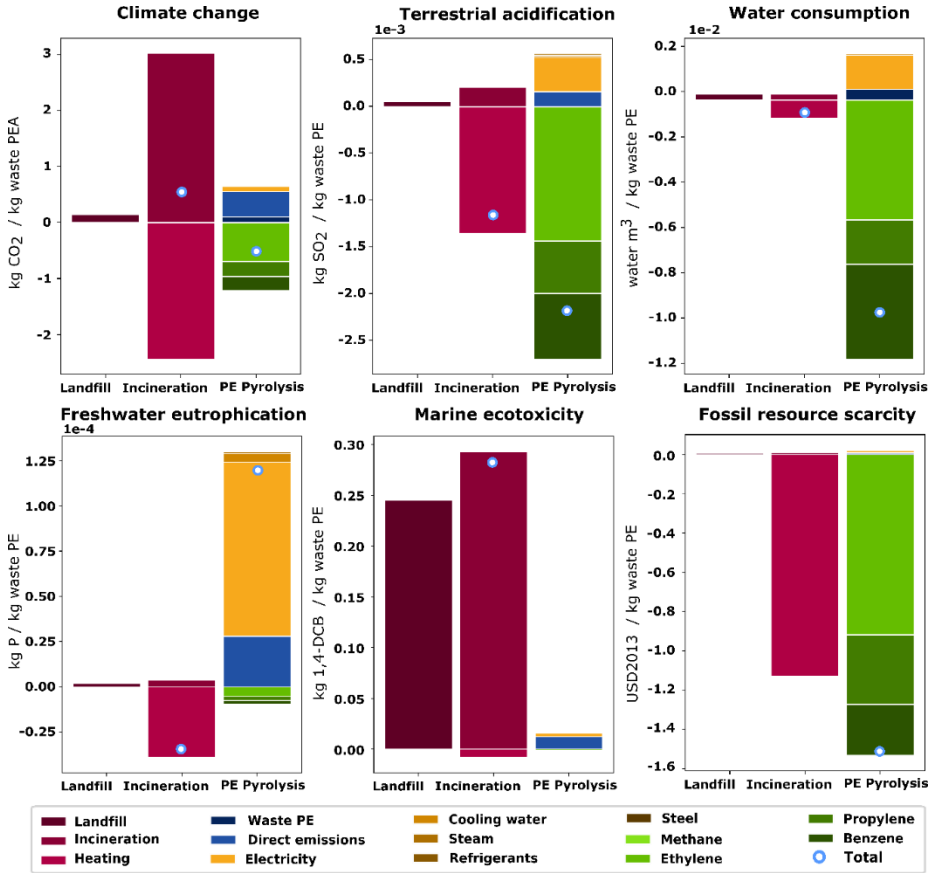

Figure 6.9. Midpoint environmental impact of end-of-life alternatives for waste PE.

The economic analysis is omitted in the work reported by Benavides *et al.* (Benavides et al., 2017). In the case of Faraca *et al.* (Faraca et al., 2019), the total cost of the pyrolysis and pretreatment processes is offset by the revenues generated from the byproducts. In the case of ethylene recovery, a net profit of 0.317 €/kg of waste PE.

These results put ethylene recovery forward as an alternative with lower carbon footprint and larger profit compared to the production of fuels. However, this can only be accomplished as long as the byproducts generated in the process are allocated in the market and proper downstream process management guaranteed. An additional advantage of ethylene recovery, along with the corresponding byproducts, is that they will typically be used to produce polymers or other chemicals that can be recycled. This contrasts with

the combustion of the fuels, where CO₂ emissions are directly release to the environment, preventing further use unless techniques such as direct air capture are used to sequester the CO₂.

From the environmental assessment at both, the cradle-to-gate and gate-to-grave systems, it is observed that the three main contributors to the negative impact are electricity, direct emissions (CO₂), and the sorting of waste PE. In terms of electricity, the alternative configuration proposed in the economic analysis, where methane is burned to cogenerate electricity, would certainly avoid the impact caused by electricity consumption. However, methane combustion would generate 0.56 kg of CO₂/kg of C₂H₄, which is more than half of the emissions already released by the process. These results reinforce that selling methane represents the best alternative from the cradle-to-gate perspective. In addition, it is also expected that the electricity mix will continue to decarbonize, reducing the environmental impact attached to this entry. As for the CO₂ emissions coming from the fuel combustion in the furnace, carbon capture techniques could be analyzed to be incorporated and reduce the impact of the process although an economic penalty would be included. Probably, the most efficient way to reduce the cost and impact attached to the sorting or pre-treatment of waste PE, is the adoption of additional policies in the collection of the polymer after use. This would not only reduce the cost and impact of this stage but also would allow a higher recycling ratio. An example of these policies and their results is Switzerland, country which recycles 51% of its municipal waste and 83% of PET bottles.

6.7. Remarks

This chapter assessed the pyrolysis of waste PE into ethylene aiming for the deployment of technologies based on the circular economy in the plastics sector. A process flowsheet was proposed according to standard heuristics and heat recovery techniques, including heat integration and the use of a steam Rankine cycle to generate electricity. The analysis of the process, carried out in terms of economic and environmental criteria, was based on the total annualized cost and the environmental indicators of the ReCiPe 2016. The process was finally compared against the business as usual (BAU) production of ethylene as well as two traditional end-of-life alternatives for waste PE.

6. Application on individual echelons

A total of 2.17 kg of waste PE are required to produce 1 kg of ethylene, 0.2 kg of methane, 0.4 kg of propylene, and 0.3 kg of benzene. The production process is highly energy-intensive, given the need to operate at 1000 °C in the furnace and the use of cryogenic temperatures in the distillation columns. However, the use of a process stream as fuel avoided the consumption of additional heating sources. Similarly, the incorporation of a steam Rankine cycle reduced by 60% the electricity consumption of the process. The final energy savings were provided by heat integration, which decreased the heating and cooling demands by 66% and 36%, respectively.

The total cost of production per kg of ethylene was 0.386 €, which represents half of the cost of the BAU process (0.835 €) reported by Spallina *et al.* (Spallina *et al.*, 2017). Similarly, the environmental performance of the PE pyrolysis presented clear advantages over the BAU process, particularly in the category of resources scarcity, where a negative impact was observed. In the comparison of the end-of-life processes, PE pyrolysis also showed better performance than landfill and incineration. This is due to the revalorization of waste PE into multiple valuable products. Despite the good environmental performance exhibited by the PE pyrolysis, it must be considered that by-products will still generate an impact in downstream processes, so care should be placed in this regard to ensure a sustainable performance over the entire life cycle.

The results presented in this chapter suggest that waste PE pyrolysis is an appealing route to close the loop in the ethylene production process, thereby enhancing the development of circular economy within the plastics and chemical sector. The results also encourage further research to generate the necessary kinetic data to properly identify, model, and optimize the products distribution in the reactor. Similarly, pre-treatment processes of waste PE should be studied and integrated in the model to enable more accurate economic and environmental assessments. Further work will also address the use of cleaner energy sources in the pyrolysis of plastics to improve the environmental performance. Overall, while there are still some data gaps and methodological choices that need further attention, mainly in the LCA calculations, this work points towards the need to study further these appealing processes as a preliminary step to encourage their widespread adoption by industry. The next chapter will assess the effect of implementing the process on the entire supply chain.

Application on the entire supply chain

7.1. Introduction

The previous chapter analyzed the effect of introducing pyrolysis into individual echelons of the PE supply chain. However, a more complete analysis is required in order to see the practical effect of closing the loop of materials on the entire supply chain. This chapter presents a broader assessment by expanding the system boundaries to consider the complete life cycle of polyethylene.

7.2. System description

Figure 7.1 shows a representation of the supply chain of polyethylene, including the most usual of the current end-of-life alternatives. Naphtha is first processed via steam cracking to produce lighter hydrocarbons, of which this section focuses on ethylene among other byproducts. Additional ethylene can also come from pyrolysis in the closed-loop approach. Then, ethylene enters the polymerization step to yield LDPE granulate, which is later processed to produce LDPE film or any other suitable packaging material. Alternatively, regenerated LDPE granulate can come from the process of mechanical recycling. The resulting product is used for packaging purposes before being disposed as waste (i.e., waste LDPE henceforth). This waste LDPE, blended in a plastic or general waste mixture, is collected and transported according to the selected end-of-life alternative. Five end-of-life options are

7. Application on the entire supply chain

considered: the three alternatives currently deployed at industrial scale (downcycling, landfilling and incineration) plus the emerging pyrolysis and mechanical upcycling, each of them generating different products (if any) with different values. These two alternatives (mechanical recycling and pyrolysis) require an intermediate sorting stage, where general waste is screened before the usable LDPE waste is separated from the remaining waste fractions. While, in general, mechanical recycling is considered one of the preferred options for waste, in the case of LDPE, downcycling is more extended. This results in the material being recycled into mainly lower-value/lower-quality applications, thereby preventing a desirable closed-loop recycling. In addition, current LDPE waste production significantly exceeds its demand on lower-value applications. When landfilled, LDPE waste is disposed without additional economic costs or profit generation although the environmental impact of this option should be still considered. Another possible end-of-life option for LDPE waste is incineration, where the polymer is burned to produce heat in the form of high-pressure steam. As described in the previous chapter, the pyrolysis of LDPE waste results in ethylene and associated byproducts. In contrast to the recycling process, where the obtained LDPE had lower quality than virgin material (LDPE is degraded when regenerated and reintroduced in the chain or used for another application), the ethylene obtained from the pyrolysis is a high-grade product which can replace virgin material narrowing the material cycles.

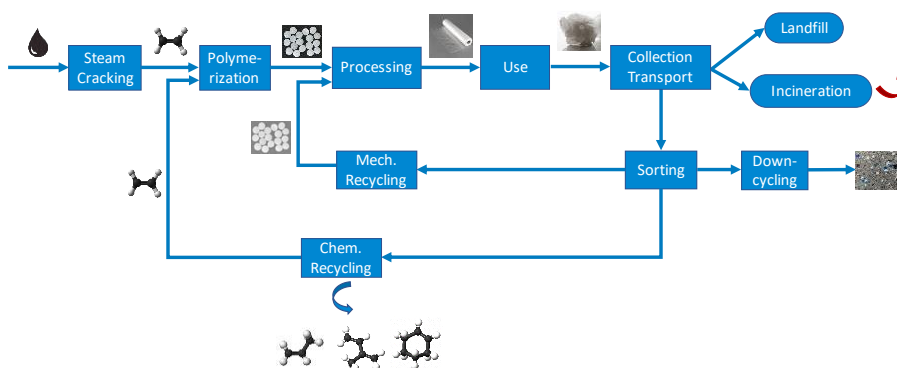

Figure 7.1. Supply chain of polyethylene.

7.3. Materials and methods

All the processes described above are modelled as black box input-output models, relating the flow of the output product i (W_i) to that of the feedstock i' ($W_{i'}$), as given by Eq. (7.1):

$$W_i = YIELD_j \cdot W_{i'} \quad \forall i, i', j | i \in OUT_j, i' \in IN_j \quad (7.1)$$

Here OUT_j is the set containing the output stream of process j while IN_j is the set containing the input stream of process j . Note that, in this formulation, material flows are only modelled for products directly connected to the LDPE life cycle (e.g., no material flows are defined for the by-products from steam cracking or pyrolysis) yet by-products are taken into account in the economic and environmental assessment via allocation of cost and impact as described in the ensuing sections.

Table 7.1. Feedstocks, products and yields for each process.

Process (j)	Main input (IN_j)	Main output (OUT_j)	Product yield ($YIELD_j$)	Reference
Steam cracking	Naphtha	Ethylene	35%	(Yoshimura et al., 2001)
Polymerization	Ethylene	LDPE pellets	100%	Assumed
Processing	LDPE pellets	LDPE film	98%	Ecoinvent, entry "Packaging film, low density polyethylene {RER} production APOS, U"
Use	LDPE film	LDPE waste (in mixed stream)	100%	Assumed

7. Application on the entire supply chain

Collection and transport	LDPE waste (in mixed stream)	LDPE waste (in mixed stream)	-	-
Sorting	LDPE waste (in mixed stream)	LDPE waste (in pure stream)	90%	Assumption
Downcycling	LDPE waste (in mixed stream)	Lower quality LDPE for other applications	-	-
Mechanical recycling	LDPE waste (in pure stream)	Higher quality LDPE	73%	(Amin, 2001)
Landfilling	LDPE waste (in mixed stream)	Landfilled LDPE waste (in mixed stream)	-	-
Incineration	LDPE waste (in mixed stream)	Heat (i.e. high-pressure steam)	42.83 MJ/kg LDPE waste (efficiency of a 60%)	Ecoinvent, entry "Heat, district or industrial, natural gas {Europe without Switzerland} market for heat, district or industrial, natural gas APOS, U"
Pyrolysis	LDPE waste (in pure stream)	Ethylene	48%	(Kannan et al., 2014)

The feedstocks and products of each process, together with the associated yields linking them are provided in Table 7.1. In the absence of data, LDPE losses during the use phase are neglected. Similarly, collection and transport stages are also neglected due to the lack of data and its high variability resulting from local policies for waste management. Note that the omission of

these two phases and losses is acceptable for comparative LCAs, where identical processes and life-cycle stages can be excluded as only the differences between the compared systems are relevant for comparing their environmental performance (European Commission - Joint Research Centre, 2010). In addition, open-loop recycle product yield is omitted from the analysis, as it is attributed to the resulting lower-grade applications.

This general system can be particularized to any region by characterizing processes using the appropriate yield, demand, cost and environmental parameters (see ensuing sections). Without loss of generality, this study is based in the EU. In particular, five different scenarios entailing distinct end-of-life options for the LDPE waste are defined.

The first scenario corresponds to the business-as-usual situation, where LDPE waste is distributed among the different end-of-life options using current shares for the EU case (World Economic Forum; Ellen MacArthur Foundation; McKinsey & Company, 2016) (see Table 7.2).

Then, five additional scenarios are considered by assuming that all the LDPE waste is treated with only one of the end-of-life options. For example, the "All to recycle" scenario assumes that all the LDPE waste is mechanically recycled after a sorting stage. According to the literature, there is a limit on the fraction of recycled LDPE that can be introduced in film without making it lose its properties (Amin, 2001). To achieve a target of 25% of regenerated LDPE, and after subtracting the percentage lost in collection and sorting stages, only a 34% of LDPE waste can be sent through this option. For the sake of a fair comparison, the 66% left is completed with the proportional business-as-usual.

The comparison between stages in the subsequent economic assessment and LCA considers a functional unit of 1kg of ethylene feeding the polymerization stage. This decision does not hamper the regional study, since unitary results can be easily scaled up to satisfy a regional demand of a certain product (e.g., the European demand for LDPE film).

Furthermore, some end-of-life option generate a different product or saving, (i.e. reduction of the ethylene from naphtha for pyrolysis, reduction of polyethylene production for closed-loop recycling, and heat generation for incineration). To ensure a fair comparison a system expansion approach is

7. Application on the entire supply chain

adopted, in which economic and environmental credits associated to the production of heat are attributed to the products that exit the system. A recycled content approach is adopted, where the burden associated to the use of waste materials is neglected. In the case of regenerated ethylene and polyethylene, no credits are given since the associated benefits are already accounted for within the system boundaries via substitution of virgin materials. As for the impact and cost of generating lower-level applications, they are transferred to the life cycle of these other applications.

Table 7.2. Current shares for plastic waste management in the EU (World Economic Forum; Ellen MacArthur Foundation; McKinsey & Company, 2016) and the other scenarios analyzed.

End-of-life alternatives (%)	Current Shares EU	All to landfill	All to incineration	All to downcycling	All to mechanical recycling	All to pyrolysis
Landfill	59	100	0	0	39	0
Incineration	20	0	100	0	13	0
Downcycling	21	0	0	100	14	0
Mechanical recycle	0	0	0	0	34	0
Pyrolysis	0	0	0	0	0	100

7.4. Economic assessment

As opposed to the economic assessment of the pyrolysis process, where both cost and revenues were studied, the focus is on the total system costs only (*TCOST*) taken as basis the functional unit (i.e., the life cycle of 1kg of ethylene entering the polymerization stage). These costs are obtained in each

scenario by adding up the individual costs of all stages j ($COST_j$) and subtracting the credits ($CRED_j$) associated to some of the processes (i.e., those in set CP , see Eq. (7.2)).

$$TCOST = \sum_j COST_j - \sum_{j \in CP} CRED_j \quad (7.2)$$

The cost of each stage $COST_j$, which considers annualized capital costs as well as operation costs, is obtained from Eq. (7.3)(7.3):

$$COST_j = UCOST_j \cdot W_i \quad \forall j, i \in CRP_j \quad (7.3)$$

where $UCOST_j$ is the unitary cost of process j per unit of cost-reference product i (e.g. €/kg), as given by set CRP_j , and W_i is the flow of the cost-reference product (e.g. kg of LDPE). Note that some processes use the output product as their cost-reference product while other use their feedstock (see Table 7.3).

Table 7.3. Cost of process j based on the reference product.

Process (j)	Cost-reference product (CRP_j)	Unitary cost ($UCOST_j$) [€/ton]	Reference
Steam cracking	Ethylene	835	(Spallina et al., 2017)
Polymerization	LDPE pellets	232	(Platzer, 1983)
Processing	LDPE film	392	(Platzer, 1983)
Sorting	LDPE waste (in mixed stream)	315	(Baldasano et al., 2003)
Landfilling	LDPE waste (in mixed stream)	98	(Baldasano et al., 2003)
Incineration	LDPE waste (in mixed stream)	128	(Gradus et al., 2017)
Mechanical recycling	LDPE waste (in pure stream)	67	(Gradus et al., 2017)
Pyrolysis	LDPE waste (in pure stream)	72	Section 6.6.1

7. Application on the entire supply chain

As described in section 7.2, credits are given to the output product of some end-of-life options of LDPE waste ($CRED_j$) in order to assume a fair comparison between the different scenarios (Eq.(7.4)).

$$CRED_j = UCRED_j \cdot W_i \quad \forall j \in CP, i \in DRP_j \quad (7.4)$$

Here, $UCRED_j$ is the unitary credit of process j per unit of credit-reference product i (e.g. €/kg), as given by set DRP_j . In this particular case, incineration is the only process receiving credits, which are provided in Table 7.4.

Table 7.4. Incineration credit product and value.

Process (j)	Credit-reference product (DRP_j)	Unitary credit ($UCRED_j$)	Reference
Incineration	Heat (i.e. high-pressure steam)	1.96 €/kJ	Aspen Database

Some remarks about the hypothesis employed to obtain unitary costs and credits follow:

- Costs from different sources were harmonized currency-wise using a 1.14 €/€ and time-wise using GDP deflators (The World Bank, 2019), so that they are all expressed in €/ton.
- In order to avoid double counting, feedstock costs are not considered in the $UCOST_j$ (e.g. the costs of LDPE pellets are already included in the production costs of processes upstream). The only exception is the first process of the network, steam cracking, whose $UCOST_j$ parameter does account for the cost of naphtha.
- Steam cracking costs only consider the portion allocated to ethylene.
- The cost of polymerization is obtained from (Platzer, 1983), neglecting the ethylene (i.e. feedstock) costs for the reasons previously exposed, and annualizing capital costs assuming a discount rate of 5% and a conservative timespan of 20 years for the plant.
- According to the literature, in the film making industry only a 25% of virgin LDPE can be replaced by regenerated LDPE if properties

want to be preserved (Amin, 2001). This limit is reflected in the unitary credits for this product, which are here assumed to be 13% of the cost of producing virgin LDPE film (Andreoni et al., 2015). To obtain the cost of producing virgin LDPE, the costs of the corresponding upstream processes are used (i.e., steam cracking, polymerization and processing).

- Regarding incineration credits, high-pressure steam produced from burning LDPE waste with a LHV of 42.83 MJ/kg (Phyllis2 database for biomass and waste, 2019) in a boiler with 60% efficiency is considered.

7.5. Environmental assessment

The goal of this LCA is to assess the impact of the whole life cycle of the polyethylene. In order to do this, a cradle-to-grave analysis considering all the process involved is performed: from the extraction of raw materials to the different end-of-life alternatives. In the absence of data, the use and the collection and transport phases are excluded from the analysis, which is acceptable for comparative assessments as the one undertaken. The functional unit considered in this phase is 1 kg of ethylene entering the polymerization stage.

Table 7.5. Impact and credits for the processes of the life cycle of polyethylene.

Process	Inventory	Credits
Steam cracking	Ecoinvent, entry "Ethylene, average {RER} APOS, U"	-
Polymerisation	Ecoinvent, entry "Polyethylene, low density, granulate {RER} APOS, U"	-
Processing	Ecoinvent, entry "Packaging film, low density polyethylene {RER} production"	-
Use	Neglected/disregarded	-

7. Application on the entire supply chain

Collection/Transport	Neglected/disregarded	-
Sorting	Ecoinvent, entry "Waste polyethylene, for recycling, sorted {Europe without Switzerland} treatment of waste polyethylene, for recycling, unsorted, sorting APOS, U"	-
Mechanical recycling	Approximation	Approximation
Landfill	Ecoinvent, entry "Waste polyethylene {Europe without Switzerland} treatment of waste polyethylene, sanitary landfill APOS, U"	None
Incineration	Ecoinvent, entry "Waste polyethylene {Europe without Switzerland} treatment of waste polyethylene, municipal incineration APOS, U"	Ecoinvent, entry "Heat, district or industrial, natural gas {Europe without Switzerland} market for heat, district or industrial, natural gas APOS, U"
Pyrolysis	Section 6.6.2	Embodied in ethylene savings

In this step, the mass balances of the system are first solved (i.e., Eq. (7.2)) to quantify the material flows entering and exiting each process (W_i) for the different scenarios (see Table 7.2). With this information at hand, then the associated environmental burdens and credits are collected from Ecoinvent database via SimaPro, except for the pyrolysis, for which the data obtained in Chapter 5 is used. Table 7.5 shows the Ecoinvent entries used to gather the LCIs for each process.

The Ecoinvent database provides life cycle impacts for these processes from a cradle-to-gate perspective. This means that all the entries include, not only the life cycle burden of the process itself (e.g., associated to the life cycle of the steel used to build the equipment), but also the burdens embodied in their feedstocks (e.g., the entry for steam cracking already includes the burdens embodied in naphtha, such as those related to raw material extraction). This implies that, for latter stages of the life cycle (e.g., starting from polymerization, continuing with processing, and so on), the burdens embodied in the feedstocks must be subtracted from the corresponding database entry to avoid double-counting. As an example, in order to obtain the LCIs of the polymerization process, the burdens embodied in the ethylene, as given by Ecoinvent entry “Ethylene, average {RER} | production | APOS, U”, must be deducted from entry “Polyethylene, low density, granulate {RER} | production | APOS, U”.

The burdens of the use and collection stages are neglected because of the lack of information and the variability of the results according to the different waste management policies. As commented above, this comprehensiveness is not required for comparative LCAs, where identical processes and life-cycle stages can be excluded as only the differences between the compared systems are relevant for comparing the environmental performance (European Commission - Joint Research Centre, 2010).

Landfilling polyethylene waste does not produce any valuable product, so no credits are assigned to this end-of-life alternative. As for incineration, credits are assigned for the heat produced to reflect the burden avoided by replacing the conventional production.

The burden of the closed-loop recycling, missing in the database, is estimated to be proportional to the burden of producing fresh material via polymerization (Andreoni et al., 2015). In particular, burdens are scaled as proportional to the energy consumption of both processes, which is 87% lower for recycling. Furthermore, closed-loop recycling results in reducing the amount of virgin LDPE granulate that is produced, which is accounted within the system boundaries.

Finally, the environmental burdens for the polyethylene pyrolysis are retrieved from the calculations in section 6.6.2, using the economic allocation as described in section 6.4 (which is not only valid for impacts but also for

7. Application on the entire supply chain

burdens). This is consistent with the burden/impact allocation for the processes sourced from Ecoinvent, since this database uses the same allocation approach. At this point, there is no need to assign credits to the ethylene produced, since the avoided fraction of fresh ethylene (i.e., from naphtha) is already accounted for within the system boundaries (allocation by system expansion).

The environmental burdens quantified in the previous step are here translated into environmental impacts by means of characterization factors. Again, the LCA ReCiPe 2016 endpoint method is used, which aggregates impacts into three endpoint indicators: human health, ecosystems and resources.

7.6. Results

7.6.1. Economic assessment

The costs and credits obtained in Chapter 6 are used to evaluate the economic performance of the five proposed scenarios (0: BAU, 1: 100% to landfill, 2: 100% to incineration, 3: 100% to open-loop recycle, 4: closed-loop recycle and 5: 100% to pyrolysis). Specifically, the results for three different variables are shown in Figure 7.2: bars provide the breakdown between the aggregated costs (i.e., sum of $COST_j$ over j , in blue) and the credits (i.e., sum of $CRED_j$ over $j \in CP$, in orange), while the yellow line read in the secondary y-axis shows the relative change of the different scenarios with respect to the BAU in terms of the total system costs ($TCOST$, as given by the difference between the aggregated costs and credits).

Comparing traditional end-of-life alternatives in terms of total costs, landfilling emerges as the less competitive alternative, with a total cost 2% higher than BAU. In addition, it offers no possibilities to further reduce the costs through credits. Incineration is the most similar alternative to the BAU case. This is because the credits of producing heat result only in a marginal reduction of the aggregated costs (less than 0.01%). Open-loop recycling is the most promising among the three. Despite the material being degraded instead of reentering the life cycle, transferring the cost and impact to these applications results into a reduction of the end-of-life cost.

Results confirm that closed-loop alternatives are highly competitive. The key driver of this advantage is the costs avoided by replacing fresh ethylene or LDPE (as illustrated by the patterned bars in Figure 7.2), which represent 19% and 16% of the aggregated costs. Note that no credits are assigned to these materials, but rather the savings are directly considered in the cost calculation as they lay within the system boundaries, due to the system expansion. While closed-loop recycle is by far the most promising, with a cost reduction of 11% with respect to the BAU, it is limited by the amount of regenerated LDPE that a new product can admit, having to rely on technology and material advances to push it forward. Pyrolysis is in second place, with a 5% reduction in cost. The higher percentage of material reintroduction pays for the higher processing costs due to the extreme operation conditions. Sorting costs are substantial and restraining the economic performance of both processes.

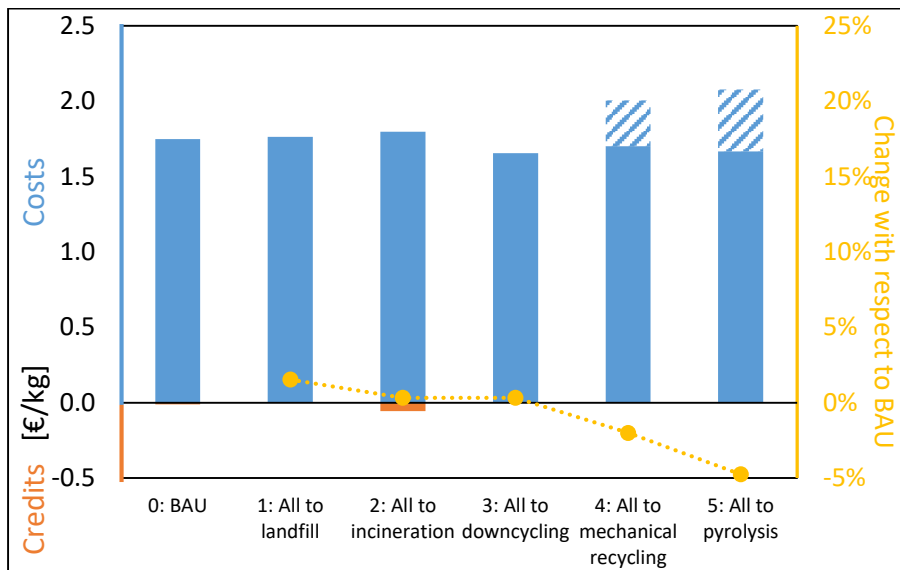

Figure 7.2. Costs, credits and change with respect to BAU for all scenarios.

7.6.2. Environmental assessment

In this section, the environmental impact of the cradle-to-grave PE life cycle is evaluated considering the different scenarios for waste treatment.

Table 7.6. Endpoint impacts of the base case and the four end-of-life scenarios.

	0: BAU	1: All to landfill	2: All to incineration	3: All to downcycling	4: All to mechanical recycling	5: All to pyrolysis
Human health [DALY]	6.03E-06	6.01E-06	6.88E-06	5.23E-06	4.28E-06	4.81E-06
Ecosystems [species-yr]	1.34E-08	1.28E-08	1.65E-08	1.22E-08	9.80E-08	1.10E-08
Resources [USD2013]	0.61	0.66	0.46	0.65	0.51	0.41

Figure 7.3 shows the comparison between the different scenarios and the base case (BAU) in the endpoint categories. The first scenario, which considers sending all LDPE waste to landfill, shows more impact on resources because of land use requirements (7%), while impact on human health and environment are equal or lower (0% and 5%, respectively) than in BAU due to avoiding the impact caused by incineration. In scenario 2, where waste is all sent to incineration, there is less impact on resources because of the credits for heat production (i.e. 25.69 MJ of natural gas avoided per kg of pyrolyzed polyethylene, which in turn result in 1.57E-06 DALY, 4.46E-09 species.yr, 0.204 USD2013 credits in each endpoint category, respectively) and also due to the significant reduction in the land used from avoided landfilling. Conversely, there is a significant increase on the impact on human health and

ecosystems because of the direct CO₂ emissions from incineration. Scenario 3, sending all to open-loop recycle, has an opposite behavior to incineration. Reductions of a 13% and 9% on the impact on human health and environment denote that it is not such a highly polluting process as incineration (25% difference in endpoint impacts of the process per kg of waste PE). Scenario 4, recycling LDPE into lower-level applications, is one of the two most promising scenarios with a 29%, 27% and 11% of reduction in human health and ecosystems, respectively. Scenario 5, sending all to pyrolysis, is the other promising scenario with the use of resources substantially reduced (33%), because PE is depolymerized and the high-quality monomer can be reintroduced into the system (i.e. recycled), replacing fresh ethylene produced from f such as naphtha. This, in combination with the direct CO₂ emissions avoided from incineration, results in the most promising scenario, environmental-wise, with savings of 20%, 18% and 33% in human health, ecosystems and resources, respectively, compared to the BAU.

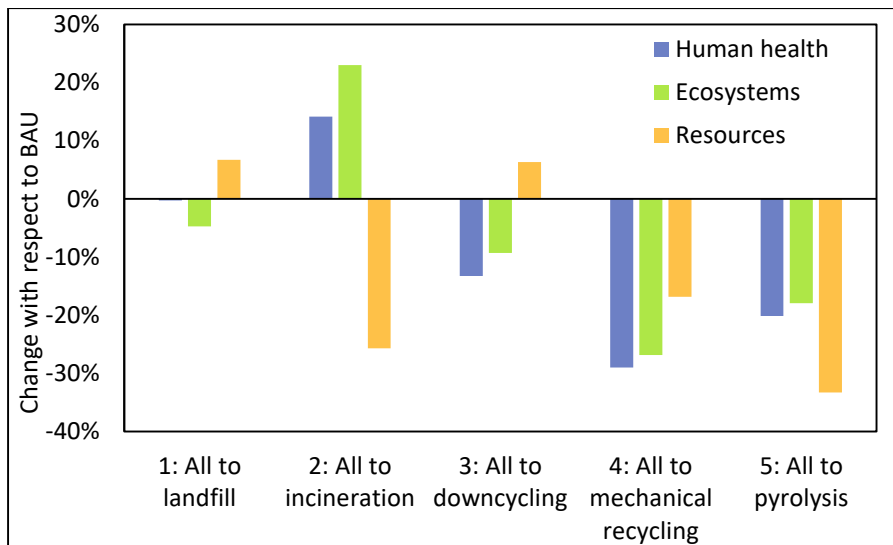

Figure 7.3. Change of environmental impacts with respect to BAU.

7.7. Remarks

The second step of the approach addressed the comparison of conventional end-of-life alternatives (i.e., downcycling, landfilling and incineration) with pyrolysis and mechanical recycling, both allowing the upcycling of materials. When the life cycle is considered, results show that costly technologies allowing material upcycling (i.e., plastic pyrolysis and mechanical recycling) have higher performance than landfilling and energy valorization of polymers having lower unitary costs. This is due to the savings achieved by cutting down the conventional production of ethylene, along with the reduction of the environmental impact. While downcycling might be seen as a cheap and environmentally-friendly option, the downgrading of materials, which must be then reused in lower-level applications, results in an overall poorer performance compared to the previous ones.

Mechanical upcycling is a very promising alternative because of its low environmental impact and cost-efficiency. However, its penetration is limited by the amount of regenerated polyethylene that a product can accept without compromising its physical properties; this situation calls for further research on improving the physical properties of polyethylene. Nevertheless, it is when such penetration limit is reached that pyrolysis becomes crucial, allowing the conversion of polyethylene into the monomer and other valuable hydrocarbons, which can then close the cycle. A limiting stage common in both alternatives is the sorting required to separate polyethylene from the plastic waste mix, underlining the need to improve collection methods to reduce sorting costs.

Part III: Preliminary steps

Generation of waste-to-resource routes

8.1. Introduction

The benefits of the circular economy paradigm have been proven in Part II. Many promising processes for chemical recycling are still under development at lab scale, so they are often disregarded when thinking about closing the materials loop. Furthermore, and opposed to traditional product-based processes, it is not always clear which is the best way to convert a specific waste stream into which added-value product(s), or even which specific waste stream will offer better economic or environmental potential to be reused or recycled. So, the synthesis of processes implementing the transformation of waste to resources is still a challenging task, which would benefit from the combination of traditional and innovative technologies in order to identify and systematically analyze the potentially efficient alternatives.

Following the methodology proposed in Chapter 4, systematic tools should be developed to address the generation of process alternatives that enhance resource upcycling. The aim of this chapter is to develop a method to synthesize and assess routes for waste-to-resource transformations.

The approach presented in this section is based on conceptualization for ontologies and knowledge modelling. An ontology is a formal, explicit specification of shared conceptualization (Studer et al., 1998). The extended use of ontologies has allowed the development of ontology-based engineering systems, providing a semantical environment and a knowledge management tool. Previous research has demonstrated the applicability of ontologies to

circular economy and industrial symbiosis problems (Cecelja et al., 2015; Raafat et al., 2013; Zhou et al., 2018).

In this chapter, a formal ontology that models the enterprise process engineering domain, so called Enterprise Ontology Project (EOP), has been used (Muñoz et al., 2013). EOP model sets well-defined domain concepts encompassed by a taxonomic arrange, terminology, definitions and relations. The domain of this ontology is process system engineering including areas such as batch processes, control and automation, planning and scheduling, supply chain management and life cycle assessment. Thus, this ontology provides to process functionalities a consistent structure for explicit, shareable and reusable formal knowledge representation.

8.2. Problem statement

The problem addressed can be stated as follows: ranging from a pre-defined ontology for the classification of waste-to-resource processes along with their specifications, and scientific documentation related to the domain of study. A list of tentative processes suitable to treat the considered waste with their specifications, such as operating conditions as well as economic and environmental data, should be determined.

Subsequently, given the previously obtained list, a set of characterized available wastes, potential products demand with quality requirements to meet, and data assessment criteria to analyze the adequacy of the process to the given waste, the objective is to determine a list of relevant technologies sorted by the criteria defined above.

8.3. Methodology

The methodology used in this work is described in Figure 8.1 and is divided into two main tasks; the first one consists of ontology selection and instantiation with information retrieved from scientific documentation, obtaining then a set of processes suitable for the domain of study. The second task consists of a reasoner that, starting from the potential transformation processes, would be able to obtain a list of processes and weight the best ones based on the assessment criteria mentioned below in section 8.3.2.

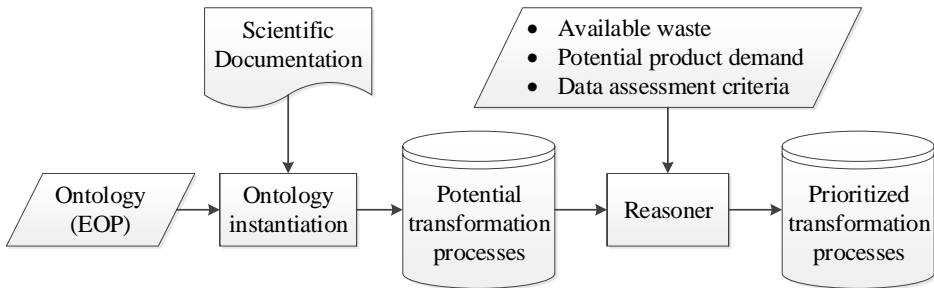

Figure 8.1. Methodology.

8.3.1. Ontological framework

An ontological framework is used to model resources, waste and potential transformation technologies considering their composition, characteristics and other specifications.

First, a set of transformation processes available in the domain of study are populated and implemented in the ontology framework mentioned above. These transformation processes have to be well defined and all the relevant parameters must be registered in the ontology.

In order to connect the available wastes with the final marketable products, an input-output matching method has to be applied, thus being able to generate different process paths (or routes) with their eventual outcomes and taking into consideration eventual intermediate products, which will enforce specific sequencing constraints.

Finally, end-of-life treatment processes for any non-marketable by-product, such as incineration for energy recovery or landfill, should be included in the proposed process network, if necessary.

8.3.2. Sorting and classification of instances (reasoner)

For each one of the transformation processes routes available in the ontology, a list is created and a ponderation is applied in order to sort them out, seeking the maximum economic and environmental profit, as well as promoting the use of simpler and more mature processes.

8. Generation of waste-to-resource routes

The process characteristics to be analyzed are sorted in three main categories: economical, environmental and matureness. Main economic aspects are: products selling price (including energy recovery benefits), waste purchase price, and processing cost. The environmental impacts of the feedstock, products and process are obtained (and eventually monetized) according to the life cycle impact model ReCiPe2016 (Huijbregts et al., 2017). And finally, the matureness of the technology is assessed with the Technology Readiness Level (TRL) as defined by the EU Horizon 2020 (European Commission, 2014).

Products prices are obtained from the Prodcom Annual Data 2018 (Eurostat - European Commission, 2018), waste prices and processes cost for the case study are taken from scientific literature review.

Then, the economic and environmental profits for every process path (the letter j is used to represent the set of processes to be studied) can be calculated as shown in Eq. (8.1) and Eq. (8.2).

$$P_{eco,j} = V_{products} - C_{waste} - C_{process} \quad (8.1)$$

$$P_{env,j} = EI_{products} - EI_{waste} - EI_{process} \quad (8.2)$$

Additionally, weighting factors are calculated in order to prioritize paths with higher economic and environmental profits against those with lower values, as shown in Eqs. (8.3,8.4).

$$f_{eco,j} = \frac{P_{eco,j} - \min_j \{P_{eco,j}\}}{\max_j \{P_{eco,j}\} - \min_j \{P_{eco,j}\}} \quad (8.3)$$

$$f_{env,j} = \frac{P_{env,j} - \min_j \{P_{env,j}\}}{\max_j \{P_{env,j}\} - \min_j \{P_{env,j}\}} \quad (8.4)$$

And another factor will be calculated from the TRL in order to promote the use of more mature technologies, as seen in Eq. (8.5):

$$f_{TRL,j} = \frac{TRL_j}{\max_j \{TRL_j\}} \quad (8.5)$$

Finally, an objective function can be calculated as shown in Eq. (8.6), which has to be maximized, that is to say, the routes with the greatest O.F. will be at the top of the list and the ones with lowest will be at the bottom.

$$OF_j = (P_{eco,j} + P_{env,j}) \cdot f_{eco,j} \cdot f_{env,j} \cdot f_{TRL,j} \quad (8.6)$$

8.4. Case study

With the purpose of illustrating the methodology, a case study has been proposed for the treatment of plastic waste, such as polyethylene waste (waste PE). A list of tentative processes has been obtained from scientific literature and other public domain sources. Other alternatives have been added, such as, direct mechanical recycling, direct downcycling, landfilling and incineration for energy recovery. A list of processes suitable for waste PE recycling has been obtained and schematized in Figure 2.

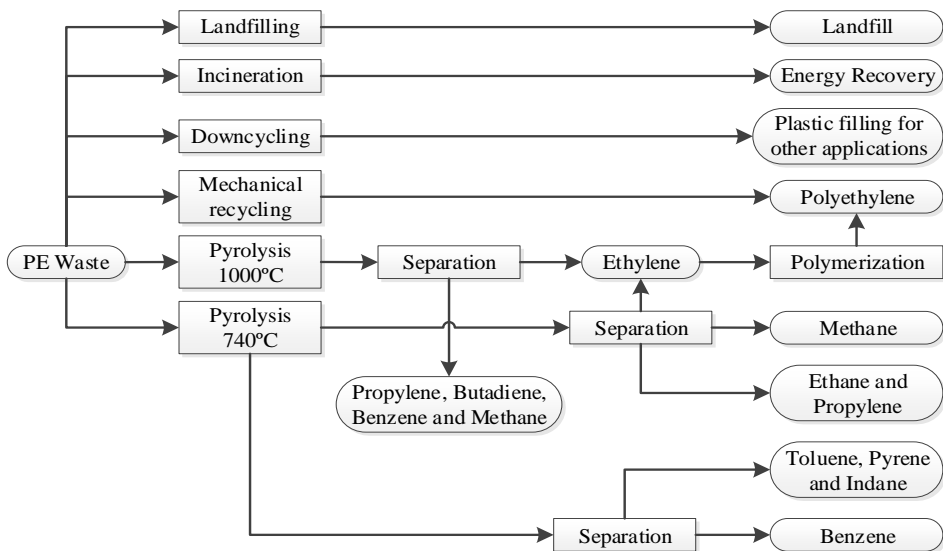

Figure 8.2. Possible alternatives for PE waste treatment.

According to the structure obtained in Figure 8.2, there are 7 different paths that can be followed for the conversion of waste into valuable products, each one of them leading to a different outcome. For simplicity purposes, the number of processes in the path generation has been limited to a maximum

of 3. Table 8.1 and Table 8.2 show the studied paths and their main specifications.

8.5. Results

Economic and environmental impacts of the processes are calculated in order to sort them out from the most profitable economically and environmentally to the less. The result is shown in Table 8.3, which is sorted by the objective function. Based on these results, the most profitable process would be waste PE pyrolysis at 740°C, followed by pyrolysis at 1000°C, along with the separation of the resulting gas and oil fractions in each case; while landfilling is found to be the less profitable option.

Chemical recycling appears to be a very promising way of treating waste and closing the materials loop, thus obtaining raw materials that can potentially be used instead of fresh raw materials. Additionally, these processes are economically and environmentally far more profitable than the traditional way of treating this kind of waste, namely landfill or incineration.

Table 8.1. Economic specifications for the analyzed processes.

Process path	Total Cost	Waste purchase price	Products Value	Economic Profit (€/t)
Pyrolysis 740°C + Separation	216.61	307.98	698.47	173.88
Pyrolysis 1000°C + Separation	215.15	307.98	695.63	172.50
Pyro. 1000°C + Sep. + Polymerization	320.60	307.98	709.93	81.35
Direct Downcycling PE	0.00	307.98	307.98	0.00
Direct Recycling PE	106.66	307.98	528.03	113.39
Incineration	128.20	307.98	493.12	56.95
Landfill	97.53	307.98	0.00	-405.51

Table 8.2. Environmental impact (E.I.) specifications and TRL of the analyzed processes.

Process path	E.I. Process (€/t)	E.I. Feed	E.I. Products (€/t)	E.I. Profit (€/t)	TRL
Pyrolysis 740°C + Separation	79.27	13.23	292.13	199.63	7
Pyrolysis 1000°C + Separation	105.27	13.23	185.47	66.97	6
Pyro. 1000°C + Sep. + Poly.	141.37	13.23	221.57	66.97	7
Direct Downcycling PE	0.00	13.23	13.23	0.00	9
Direct Recycling PE	139.68	13.23	125.87	-27.04	8
Incineration	209.35	13.23	162.37	-60.21	9
Landfill	19.10	13.23	0.00	-32.33	9

Table 8.3. Results and weighting parameters for the different process paths.

Process path	Economic factor	Environmental factor	TRL factor	O.F.	Global position
Pyrolysis 740°C + Separation	0.98	1.00	0.78	1041.90	1
Pyrolysis 1000°C + Separation	0.98	0.64	0.67	516.69	2
Pyro. 1000°C + Sep. + Poly.	0.89	0.64	0.78	510.35	3
Direct Downcycling PE	0.82	0.46	1.00	376.03	4
Direct Recycling PE	0.92	0.39	0.89	344.85	5
Incineration	0.87	0.30	1.00	258.48	6
Landfill	0.44	0.37	1.00	92.88	7

8.6. Remarks

This section presents a methodology for the systematic generation of a list of potential waste-to-resource technologies based on the use of ontologies. Thanks to this method, new technologies can be identified and compared to others that are well-established, and a manageable list of technologies can be obtained for further optimization and superstructure analysis, as well as a more profound development.

The growing application of circular economy principles entails the emergence of new waste-to-resource technologies, such as chemical recycling. A fair evaluation of the potential technologies has to consider its TRL, as its application is riskier than the one of well-established alternatives. Thus, the proposed objective function includes a factor to assess the maturity of the technology.

The framework also allows the generation of routes based on linking consecutive processes in a building-blocks approach. This method leads to flexible product compositions, aiding decision-makers to identify the most economically and environmentally beneficial solutions.

With the aim of ensuring that the list of alternatives includes the most up-to-date transformation technologies, future work will address the development of a procedure for the systematic search of waste-to-resource processes.

Targeting material exchanges

9.1. Introduction

Next step in the proposed methodology is the targeting of material exchanges (see Chapter 4). The aim of this section is to develop simple yet efficient targeting methods to evaluate the extent to which circular economy can be applied at a system. First, chemical balances are applied to bound chemical transformation in section 9.2. An extended version is used in section 9.3 to identify the most promising synergies when designing eco-industrial parks while discarding infeasible links.

9.2. Chemical targeting

Figure 9.1 shows the atomic balances of the case study that will be solved in Chapter 10. Five plastic waste inlets and demands for 10 bulk chemical demands are considered (further detail in section 10.5). There is a clear gap between collected waste and material demand to satisfy, leading to plastic waste only capable of covering up to 19% of bulk chemicals demand. Thus, even if waste is transformed recycled to the top of its potential, the remaining 81% must be outsourced. This naive upper bound (economic, chemical or thermodynamic limitations are not considered) can be used to limit the network optimization model but also stressed the need of working on more efficient waste collection and sorting techniques.

9. Targeting material exchanges

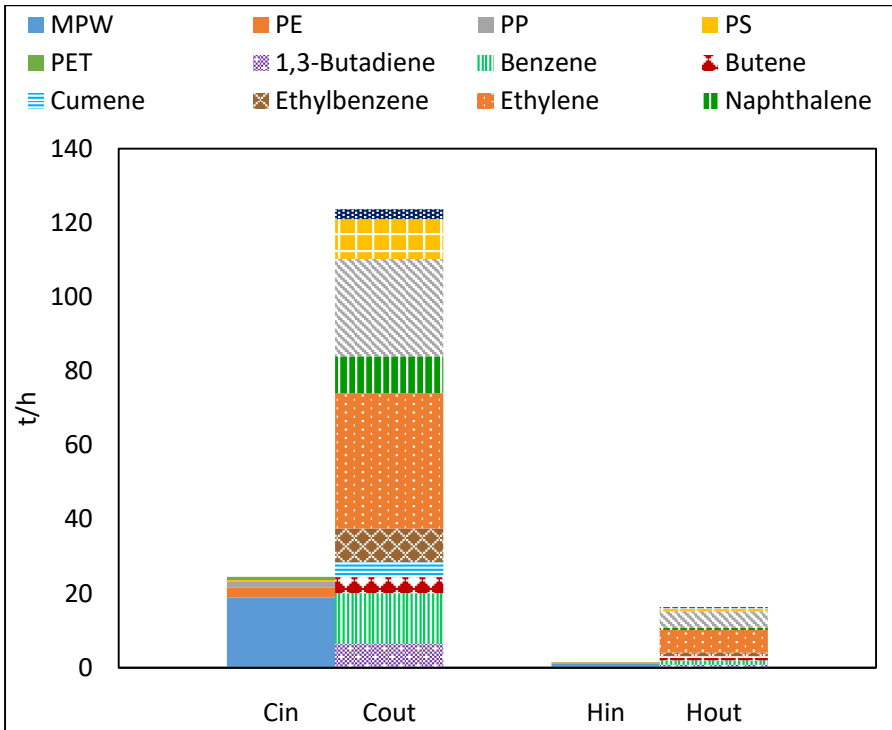

Figure 9.1. Chemical balances for material exchange targeting.

9.3. Extended targeting

In the last years, there has been a growing awareness of the importance of applying circular economy approaches to close material, energy and water cycles (Merli et al., 2018). With their focus on closing loops in industrial processes, Industrial Symbiosis (IS) principles have been widely applied in many specific sectors (van Ewijk et al., 2018; Deschamps et al., 2018). A shared concern is engaging industries to join: the more participants are involved, the better environmental performance is achieved.

However, current eco-industrial parks (EIP) and resource exchange designs are mainly ad-hoc Industrial Symbiosis approaches, based on identifying opportunities through expert analysis. These strategies, even after a systematic local search, usually lead to sub-optimal solutions. In light of this, there is a need of systematic methods aimed at coping with the complexity

of the problems by exploring only feasible and promising alternatives. Previous works have focused on the development of tools for transformation companies that might make profit of connecting sources and sinks of resources, and thus reducing the final waste involved (Somoza-Tornos et al., 2017 and 2018).

A material network is designed to model the exchange of materials that become profitable for the involved actors (sources, transformers and sinks). Conservation laws and thermodynamic constraints are used to discern between the resulting alternatives.

9.3.1. Problem statement

The system under study is illustrated in Figure 9.2.

The targeting problem can be stated as follows: Given a set of waste streams j that could be potentially treated to satisfy the raw materials demand of streams k ; a set of chemical reactions that may take place between the i products composing the mentioned streams: and other available data, including complete economic data, technical constraints and thermodynamic parameters. The decisions to be made comprise the amount of waste processed by the system, whether or not it is transformed, the requirements of external feeds or demands, how the products are distributed to satisfy the needs of customers and which side products have to be disposed.

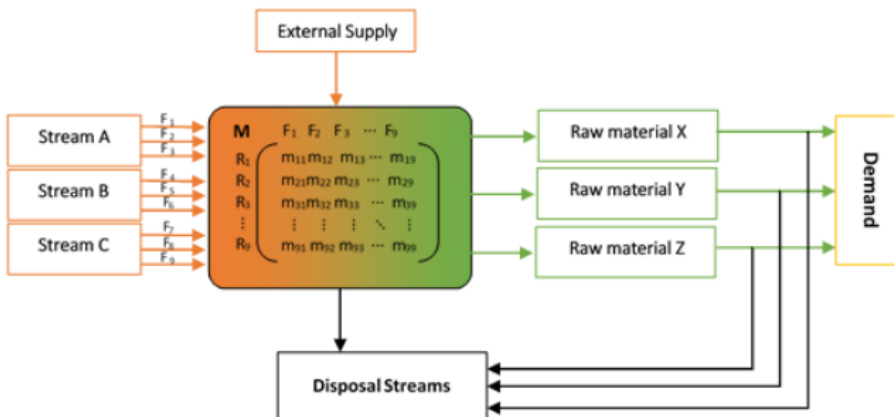

Figure 9.2. Material network scheme.

9.3.2. Mathematical formulation

The problem is formulated as a MILP that finds the optimal synergies between waste producers and raw materials consumers.

The total inlet to the system includes waste streams W_{ji} and potential supply of products required to complete the transformation ES_i (Eq. (9.1)).

$$\sum_j W_{ji} + ES_i = F_i^{in} \quad \forall i \quad (9.1)$$

Eq. (9.2) defines the mass balance of the system considering the inlet, outlet and generation terms, the last one calculated through stoichiometric coefficients R_{mi} and the extent of the reaction F_m^{gen} .

$$F_i^{in} + (\sum_m R_{mi} \cdot F_m^{gen}) = F_i^{out} \quad \forall i \quad (9.2)$$

The result of the transformation F_i^{out} is then divided in two, the amount sent to customers F_{ki}^{rm} and the side products that are unassigned F_{li}^d (Eq. (9.3)). This balance is completed with the introduction of the term F_i^{ed} to represent the external demand that new partners may have.

$$F_i^{out} = \sum_k F_{ki}^{rm} + \sum_l F_{li}^d + F_i^{ed} \quad \forall i \quad (9.3)$$

z_k is defined in Eqs. (9.4,9.5) as a binary variable that takes a value of 1 if the amount sent to the customers, F_{ki}^{rm} , is greater than the demand.

$$D_{ki} \cdot z_k \leq F_{ki}^{rm} \quad \forall k, i \quad (9.4)$$

$$F_{ki}^{rm} - D_{ki} \leq M \cdot z_k \quad \forall k, i \quad (9.5)$$

Hence, when the demand is surpassed, the profit of selling C_k it is penalized with a cost for the excess of delivery C_k^d .

$$f_k^1 \leq M \cdot z_k \quad \forall k \quad (9.6)$$

$$f_k^1 \leq (\sum_i D_{ki} \cdot C_k) - C_k^d \cdot \sum_i (F_{ki}^{rm} - D_{ki}) \quad \forall k \quad (9.7)$$

On the contrary, when demand is not covered, only the amount sent to the customer must be taken into account for the profit calculation.

$$f_k^2 \leq M \cdot (1 - z_k) \quad \forall k \quad (9.8)$$

$$f_k^2 \leq (\sum_i F_{ki}^{rm} \cdot C_k) \quad \forall k \quad (9.9)$$

The energy balance of the system is calculated as in Eq. (9.10), where Q_m^{exc} denotes the amount of energy added or extracted from the system.

$$(\sum_i R_{m,i} \cdot F_m^{gen} \cdot H_i) = Q_m^{exc} \quad \forall m \quad (9.10)$$

Binary variable y_m is defined in Eqs. (9.11,9.12) to differentiate processes that require heating or cooling and apply costs accordingly.

$$Q_m^{exc} \leq M \cdot y_m \quad \forall m \quad (9.11)$$

$$-Q_m^{exc} \leq M \cdot (1 - y_m) \quad \forall m \quad (9.12)$$

Eqs. (9.13,9.14) apply when heat is extracted from the system, and cost parameter CQ_{out} is considered.

$$f_m^3 \leq M \cdot y_m \quad \forall m \quad (9.13)$$

$$-f_m^3 \leq Q_m^{exc} \cdot CQ_{out} \quad \forall m \quad (9.14)$$

Conversely, when heat is added to the system, the cost is calculated through Eqs. (9.15,9.16).

$$f_m^4 \leq M \cdot (1 - y_m) \quad (9.15)$$

$$-f_m^4 \leq -Q_m^{exc} \cdot CQ_{in} \quad (9.16)$$

The objective function to be maximized is the economic balance shown in Eq. (9.17). It considers the profit obtained from satisfying the demand of current companies and potential new partners. Aggregated cost parameters associated with the different transformation routes are considered at this step. These aggregated costs, including capital and operational costs plus indirect costs like transportation and management, must be estimated according to the specific circumstances, and the sensibility of the results to these estimations must be adequately assessed.

$$OF = - \left(\sum_i \sum_l F_{li}^d \cdot C_l \right) - \left(\sum_i \sum_j W_{j,i} \cdot C_j \right) - \left(\sum_m F_m^{gen} \cdot C_m^R \right) - \left(\sum_i ES_i \cdot C_i^{es} \right) + \left(\sum_i F_i^{ed} \cdot C_i^{ed} \right) + \sum_k f_k^1 + \sum_k f_k^2 - \left(\sum_m f_m^3 + \sum_m f_m^4 \right) \quad (9.17)$$

The resulting model for the targeting can be posed as follows:

TSym min [OF]

s.t. Eqs. (9.1,9.17)

9.3.3. Case study

The capabilities of the model are illustrated in a case study consisting of an eco-industrial park based on ethylene and chlorine, with 10 available waste streams and 7 demands of raw material have been defined. The considered compounds include acetic acid, benzene, chlorine, vinyl chloride, ethanol, ethylbenzene, ethylene, ethylene dichloride, ethylene oxide, hydrochloric acid, oxygen, tetrachloroethylene, trichloroethylene, vinyl acetate and water. Eqs. (9.18-9.26) show the reactions that the park would consider can take place between the components by a transformation company.

9. Targeting material exchanges

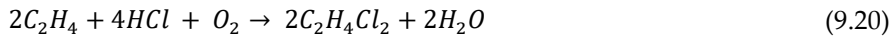

9.3.4. Results

The resulting MILP problem, featuring 1209 equations, 1064 continuous variables and 159 binary variables, has been modeled in GAMS 23.8.2 and solved with CPLEX 12.4.

Four different scenarios have been defined to examine the chances of incorporating new participants in the symbiotic network. These new participants can either be a source of waste or raw materials consumers, all presenting their own capacity limitations.

- a) Base case of the existing eco-industrial park (EIP)
- b) New companies could join the EIP and offer new sources of waste
- c) New partners could join the EIP and take advantage of generated waste
- d) New companies could both as a source and sink of resources

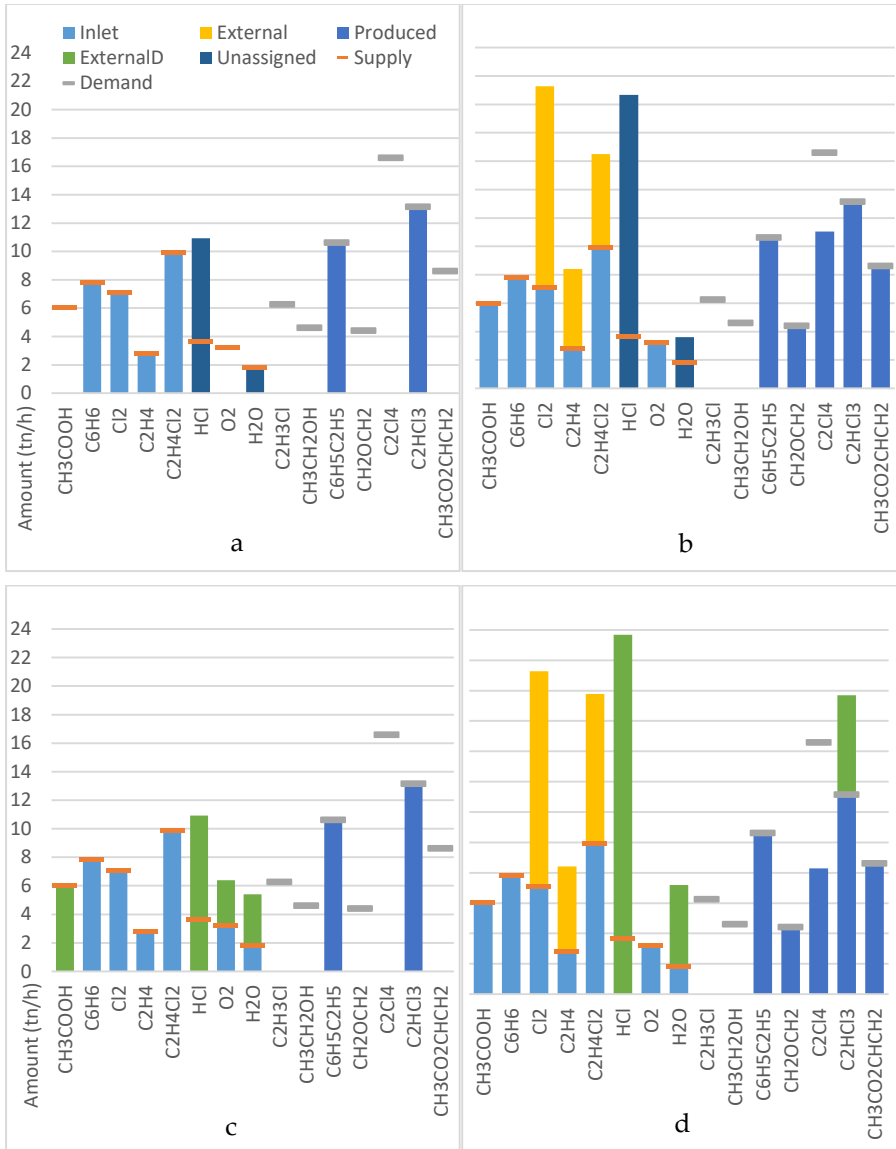

Figure 9.3. Waste usage and raw materials satisfaction for scenarios a, b, c, d.

Figure 9.3. Waste usage and raw materials satisfaction for scenarios a, b, c, d. Figure 9.2.a depicts the waste usage and the raw materials demand satisfaction for the existing IIP. The first case, where no external supply is available, is constrained by the limit in the waste supply. Reactions (9.22) and (9.26) are active to produce ethylbenzene and trichloroethane. The lack of

9. Targeting material exchanges

ethylene does not allow acidic acid to be used in reaction (9.25) and there are sources of an excess of HCl and water that is not reused.

Figure 9.2.b shows the effect of finding new partners that may be a source of waste. By adding new producers of chlorine, ethylene and ethylene dichloride to the park, more of the demands are internally covered and thus the external requirements of raw materials are reduced. Transformations (9.19), (9.24) and (9.25) would have to be activated to produce ethylene oxide, tetrachloroethylene and vinyl acetate, thus increasing the amount of waste processed and the profit of the entire complex. This would increase even more the excess of side products.

In Figure 9.2.c the opposite case is represented, where new partners would only be interested in raw materials production. As the waste supply was limiting the base case, only the side products in excess can be used, resulting in a reduced grow of the EIP.

When these limitations are overcome in Figure 9.2.d, the most promising ways of making the EIP grow are identified, and so are the transformations that the policy-makers should foster.

9.3.5. Remarks

This chapter has addressed the development of a tool to identify the most promising routes to match sources and sinks of resources, even when a transformation step is required. This will help to reduce the complexity of the analysis required during the synthesis and design of industrial processing networks. Hence, the model offers policy-makers a method to systematically identify and assess opportunities for increasing the integration of process networks in industrial complexes. Thus, Administrations may use their resources to incentive partners that will ensure economically feasible synergies with the ultimate goal of reducing waste. An adequate reformulation of the objective function may also allow these companies to identify their opportunities, and even the different members of the industrial network the best cooperation opportunities (multi-objective approach). Future work will also focus on the application of combined targeting-synthesis methodologies to systematically analyse in detail the resulting proposals.

**Part IV: Decision-making tools for the
implementation of circular economy
principles in process systems**

Synthesis of circular economy networks

10.1. Introduction

All the previous steps (establishing criteria to evaluate transformation technologies in Chapter 5, building waste-to-resource routes in Chapter 8 and targeting the potential for material exchange in Chapter 9) are the preliminary tasks towards the development of a model for the synthesis of circular economy networks, on which this chapter focuses.

Regarding the systematic exploration and assessment of opportunities, it is worth mentioning the detailed review of Boix et al. (2015) on optimization in industrial symbiosis. Despite recent advances, most of the research challenges identified by Boix et al. (2015) remain, including the possibility of transforming external waste streams considered in this work. Substantial research effort has been dedicated to the retrofitting of existing EIPs. Works are numerous, especially on water exchange networks (Aguilar-Oropeza, Rubio-Castro, and Ponce-Ortega (2019) worked on finding the utopian point for water recycling and reuse; Aviso (2014) developed a robust optimization model for stochastic modelling; Huang et al. (2019) proposed a stochastic model for the design of industrial water desalination; Jiang et al. (2019) considered the joint use of water utility system; Montastruc et al. (2013) study the flexibility of water networks in industrial symbiosis; O'Dwyer et al. (2020) take into account spatial effect on the network design; Tiu and Cruz (2017) focus on water quality considerations; Xu et al. (2019) study fault propagation in water networks); energy exchange networks (Zhang et al., (2017) consider knowledge management for energy utilization; Bütün, Kantor and Maréchal, (2019) include spatial considerations; Knudsen, Kauko and Andresen, (2019)

design a model for surplus-heat allocation); and their integration (Aziz and Hashim, 2019; Leong et al., 2017a).

All these works provide valuable tools to assess the synthesis and development of EIPs. However, they are frequently case-based, geographically limited, or only focused on the exchange of utilities (mainly heat and water), for which the transformation processes are implicit or negligible.

But material exchanges entail specific challenges: the number of flows to manage, their potentially different nature and characterization, and the number of actors involved (i.e., the different industries that take part in the system, the requirements from the administration and other third parties). Furthermore, upgrading material waste (e.g. polyethylene waste) into reusable resources (e.g. ethylene) require complex and specific transformation technologies (e.g. separation processes and/or specific chemical reactions, such as pyrolysis), which need to be included in the model if the related opportunities are to be systematically explored.

Focusing on the complexities of the generic problem of resources transformation and exchange, Maillé and Frayret (2016) developed a MILP formulation to optimize by-product flows, synergy configurations, and investment decisions in eco-industrial networks; Ren et al. (2016) developed a multi-objective model based on emergy indexes and Tan et al. (2016) considered cooperation between industries. More recently, Al-Fadhli, Baaqeel, and El-Halwagi (2019) extended their previous works on targeting Carbon-Oxygen-Hydrogen symbiosis networks by adding modular design and natural resource limitations. The works by this research group (Noureldin and El-Halwagi, 2015; Panu et al., 2019; Topolski et al., 2018) have brought a consistent framework for material exchange centered in EIPs.

This work proposes a wider scope beyond the conceptual limits of an EIP, by considering external waste supply, as well as the integration of efficient transformation processes for material upgrading (e.g. pyrolysis) instead of conventional waste treatment processes leading to lower grade resources (e.g. waste to energy via incineration). Consequently, the assessment of alternatives will not be limited to the analysis of the economic performance of the processes: Environmental performance should be included in the evaluation, in order to guarantee the effect of waste transformation processes when com-

pared to traditional end-of-life alternatives for waste. In this regard, Life Cycle Assessment (LCA) metrics provide detailed estimations of the environmental impacts of said processes.

Although utilities exchange and by-product synergies are potentially beneficial in both economic and environmental terms, the opportunities in considering the transformation of urban or industrial waste into added-value products are limitless. This raises the concern on the feasibility of the examination of the possible conversion routes, in order to select the most convenient one. In contrast with the more constrained number of possibilities to be considered for the synthesis of traditional product-based process industries, this waste-to-resource approach requires an efficient screening method to study all the opportunities.

The aim of this work is contributing with an optimization model for the identification and assessment of the most appealing processes among a set of potential alternatives, able to provide decision making support in waste revaluation projects and synthesis of industrial symbiosis networks. With this goal, the model is aimed at building a network encompassing potential alternative processes (i.e., different waste-resource routes) that could be implemented to close the loop between waste producers and resource consumers.

10.2. Problem statement

Based on the general problem statement defined in section 4.1, the screening problem addressed in this work can be stated as follows:

- Given are a set of available waste streams and a set of technologies that can transform them into added-value products.
- Given are also target demands for final products and the possibility of outsourcing some of the components required as final products or reactants in the transformation processes, and the end-of-life alternatives to dispose valueless by-products or idle waste.
- The aim is to determine the optimal processing network that maximizes the symbiosis opportunities under different criteria (e.g. maximizing profit and reducing environmental impact). The network is modeled as a superstructure including as decisions the amount of waste to be disposed through the different end-of-life alternatives

and the amounts of processed waste, outsourced components and products sold.

10.3. Mathematical formulation

The proposed framework is built over a mathematical model adapted from the one proposed by Kim, Sen, and Maravelias (2013) for the assessment of biomass-to-fuel processes, by extending it with new elements required for the modeling of industrial symbiosis networks. These new elements include the consideration of waste as the main inlet resource, the possibility of outsourcing materials (to cover need of reactants for waste-to-resource transformations that are not present in waste streams or to cover product demands that cannot be satisfied through waste transformation) and the consideration of alternative paths for waste treatment (i.e. waste is disposed or degraded into material or energy for lower level applications).

The global mass balance of the system is shown in Eq. (10.1). For any compound i in the model, the amount of waste purchased (P_i) plus the outsourcing needs (O_i) and the amount produced/consumed by the waste-to-resource technologies j ($\sum_j \eta_{ij} X_j$) must be equal to the amount sold to final consumers (S_i) plus the amount of non-demanded products send to end-of-life alternative k (waste disposal, $\sum_k W_{ik}$).

$$P_i + O_i + \sum_j \eta_{ij} X_j = S_i + \sum_k W_{ik} \quad \forall i \quad (10.1)$$

where variable X_j denotes the production level of technology j and η_{ij} is a parameter defining the yield of component i in technology j , whose values are positive for produced components and negative for the ones consumed.

This formulation admits several types of material exchange: waste can be processed ($P_i = -\sum_j \eta_{ij} X_j$, for consumed compounds, e.g. waste plastic that is sent to pyrolysis), directly sold if it matches the outlet requirements ($P_i = S_i$, e.g. plastic sent to an industry that can directly reuse it) or disposed ($P_i = \sum_k W_{ik}$, e.g. plastic that cannot be recycled and is thus disposed or incinerated for its revaluation); outsourcing can enter the transformation process ($O_i = -\sum_j \eta_{ij} X_j$, for consumed compounds, e.g. compounds not present in waste streams but that are required as reactants at waste-to-resource transformations) or be directly sold to match a lack of any component after direct

exchange or transformation ($O_i = S_i$, e.g. when ethylene recovered from plastic pyrolysis is not enough to cover the total demand of ethylene, so new ethylene is additionally introduced as raw material).

Sold compounds cannot exceed the demand (ω_i) for all products $i \in I^{PRO}$ as represented in Eq. (10.2).

$$S_i \leq \omega_i \quad \forall i \in I^{PRO} \quad (10.2)$$

The different technologies available have minimum and maximum capacity limitations ($\underline{\beta}_j, \bar{\beta}_j$) imposed on their main production level (X_j), as given by Eq. (10.3):

$$\underline{\beta}_j \leq X_j \leq \bar{\beta}_j \quad \forall j \quad (10.3)$$

Subsets of components i are required to bound variables: $i \in I^{WST}$ for waste sources, $i \in I^{OUT}$ for outsourced components, $i \in I^{PRO}$ for products and $i \in I^{BYP}$ for by-products. Only waste and outsourced components can be purchased (Eqs. (10.4,10.5)), and the corresponding amount is limited by maximum availability ($\bar{\delta}_i, \bar{\gamma}_i$) (Eqs. (10.6,10.7)). Note that a minimum allowable purchase could also be established if necessary with analogous equations and parameters ($\underline{\delta}_i, \underline{\gamma}_i$).

$$P_i = 0 \quad \forall i \notin I^{WST} \quad (10.4)$$

$$O_i = 0 \quad \forall i \notin I^{OUT} \quad (10.5)$$

$$P_i \leq \bar{\delta}_i \quad \forall i \in I^{WST} \quad (10.6)$$

$$O_i \leq \bar{\gamma}_i \quad \forall i \in I^{OUT} \quad (10.7)$$

$$S_i = 0 \quad \forall i \notin (I^{PRO} \cup I^{BYP}) \quad (10.8)$$

The solution of industrial symbiosis problems requires the implementation of multi-objective optimization techniques to assess the different dimensions of sustainability. As in the case of Kim, Sen, and Maravelias (2013), the proposed formulation accepts different criteria for strategy evaluation. Here, the maximization of the global profit of the system and the minimization of its environmental impact are considered. These are the objectives that policy makers would consider when looking at the life cycle of materials (raw material acquisition, process and disposal) to identify the most promising waste transformation technologies. Eq. (10.9) represents the maximization of the profit, including the income for selling the products or by-products, the cost

of waste and outsourced compounds, the cost for disposal and the cost of transformation.

$$\begin{aligned}
 \max Profit = & \sum_{i \in (I^{PRO} \cup I^{BYP})} \lambda_i^S S_i & (10.9) \\
 & - \sum_{i \in I^{WST}} \lambda_i^P P_i \\
 & - \sum_{i \in I^{OUT}} \lambda_i^O O_i \\
 & - \sum_{ik} \mu_{ik}^W W_{ik} \\
 & - \sum_j \sigma_j X_j
 \end{aligned}$$

Eq. (10.10) shows the objective function to minimize environmental impact, including impacts embedded in purchasing waste and outsourced materials, treating waste and the transformation processes.

$$\begin{aligned}
 \min Env. Imp. = & \sum_{i \in I^{WST}} \varepsilon_i^P P_i & (10.10) \\
 & + \sum_{i \in I^{OUT}} \varepsilon_i^O O_i \\
 & + \sum_{ik} \varepsilon_{ik}^W W_{ik} \\
 & + \sum_j \varepsilon_j^X X_j
 \end{aligned}$$

10.3.1. Stochastic model

The scarcity of available data together with the low degree of development of some of the revalorization processes may lead to elevated levels of uncertainty. To attain them, we rely on scenario sampling for the discretization of the uncertain distributions of the associated stochastic parameters. A set of M potential scenarios ($m = 1, \dots, M$) is defined. Continuous variables are then modified since their values will depend on the selected scenario ($P_{mi}, S_{mi}, O_{mi}, W_{mik}, X_{mj}$) and a binary variable B_j is added to enforce that a single network design is considered for all these scenarios. Expected values for the objective function is calculated by multiplying the profit obtained for each scenario by its probability ρ_m Eq. (10.11).

$$\begin{aligned}
\max Profit = & \sum_m \rho_m \cdot (\sum_{i \in (I^{PRO} \cup I^{BYP})} \lambda_i^S S_{mi} - & (10.11) \\
& \sum_{i \in I^{WST}} \lambda_i^P P_{mi} \\
& - \sum_{i \in I^{OUT}} \lambda_i^O O_{mi} - \sum_{ik} \mu_{ik}^W W_{mik} - \sum_j \sigma_{mj} X_{mj}) \\
\text{s.t.} \quad & g_m(P_{mi}, S_{mi}, O_{mi}, W_{mik}, X_{mj}, B_j) = 0 \\
& h_m(P_{mi}, S_{mi}, O_{mi}, W_{mik}, X_{mj}, B_j) \leq 0
\end{aligned}$$

10.4. Solution procedure

Figure 10.1 depicts a diagram for the solution strategy followed to obtain the results. Values for deterministic and discretized uncertain parameters, in addition to the set of objectives to optimize, are sent to the model. Environmental objectives (each of the three considered endpoints) are assessed against profit through the representation of bicriteria Pareto fronts. The ε -constraint method (Mavrotas, 2009) is used to generate the set of Pareto optimal solutions. To do this, the strong anchor points for each bicriteria pair are first found. With this information, the values of ε can be calculated and the model is solved iteratively to find all the points of the Pareto set.

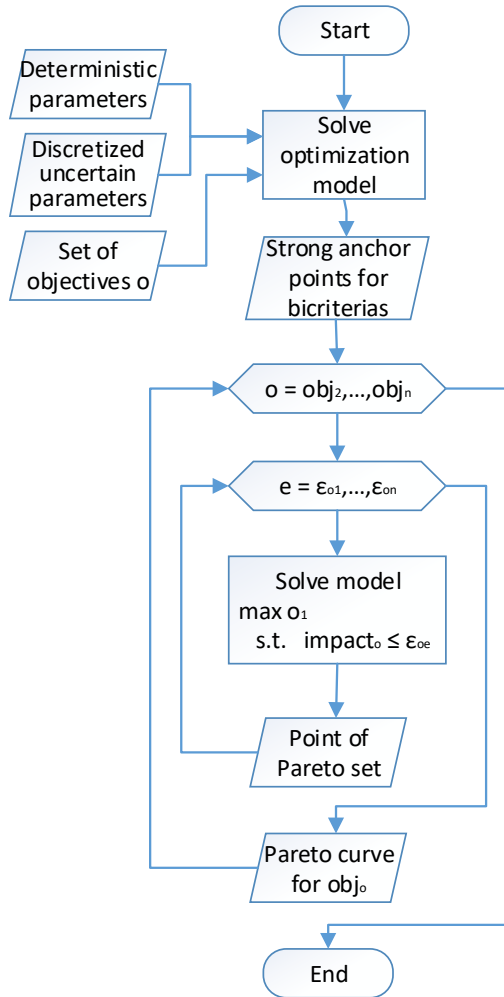

Figure 10.1. Flowchart of the solution procedure.

10.5. Case study

This section illustrates the capabilities of the model through its application to the prospective analysis of the pyrolysis of mixed plastic waste for the upcycling of value-added chemicals. 17.6 million tons of plastic waste were generated in the EU28 during 2016 (Eurostat - European Commission, 2016), of which 8.4 million tons were collected for its recycling (PlasticsEurope, 2018). End-of-life alternatives for plastic waste include its landfilling, incineration,

mechanical recycling and depolymerization. During the past decades, recycling alternatives are attracting wide interest. The high valorization potential comes along with the difficulty to assess on which alternatives are more profitable, not only for the endless possibilities but also because most technologies for depolymerization are still in a research and development stage (i.e. their technology readiness level is low) (World Economic Forum; Ellen MacArthur Foundation; McKinsey & Company, 2016). Though promising, pyrolysis of plastic waste is still in a low technology readiness level. The data required for assessing its industrial application is scarce, with most of the published results obtained from laboratory-scale experiments. Hence, data for product distribution from several experimental contributions is gathered from the literature and costs for their industrial application are estimated.

An available inlet of polyethylene (PE), polypropylene (PP), polystyrene (PS), polyethylene terephthalate (PET) and mixed plastic waste (MPW) is considered (amounts in Table 10.1). Taking into account that in Europe, over 8.4 million tonnes of plastic waste were collected in recyclable designated sites in 2016 (PlasticsEurope, 2018), this is the equivalent of the mixed plastic waste produced by 5.4 million people. The case study is scaled to treat the typical waste produced in a western industrialized area populated by 5 million people. Processes are designed based on the capacity of a waste incineration in the outskirts of Barcelona (20 t/h). Waste purchasing costs are estimated in Table 10.1 taking into account the price for waste plastic (Eurostat - European Commission, 2019) and the contribution to the prices from each one of the polymers according to its market price (Eurostat - European Commission, 2018).

Table 10.1. Amount of available waste inlets.

Waste	Amount (t/h)	Cost (€/t)
Mixed Plastic Waste (MPW)	20.00	306.00
Polyethylene (PE)	2.92	307.98
Polypropylene (PP)	1.65	269.63
Polystyrene (PS)	0.51	559.02
Polyethylene terephthalate (PET)	0.96	228.09

Table 10.2. Transformation processes, reference and main products.

Process	Reference	Main products (with a fraction >5%, in decreasing order)
Sorting of MPW	(Brandrup et al., 1996; Onwudili et al., 2018)	Polyethylene (PE), polystyrene (PS), polyethylene terephthalate (PET), polypropylene (PP)
Pyrolysis of MPW at 600°C	(Onwudili et al., 2018)	Gas and oil fractions
Pyrolysis of PE at 1000°C	(Kannan et al., 2014)	Gas fraction
Pyrolysis of PE at 740°C	(Kaminsky et al., 2004)	Gas and oil fractions
Pyrolysis of PP at 760°C	(Kaminsky et al., 2004)	Gas and oil fractions
Pyrolysis of PS at 425°C	(Onwudili et al., 2009)	Oil fraction
Separation of gas components from MPW pyrolysis at 600°C	(Onwudili et al., 2018)	Hydrogen, methane, propylene, butane, ethane, ethylene, propane, butene
Separation of light oil components from MPW pyrolysis at 600°C	(Onwudili et al., 2018)	Toluene, benzene, styrene, ethylbenzene
Separation of gas components from PE pyrolysis at 1000°C	(Kannan et al., 2014)	Ethylene, propylene, benzene, 1,3-butadiene, methane
Separation of gas components from PE pyrolysis at 740°C	(Kaminsky et al., 2004)	Methane, ethylene, ethane, propylene
Separation of light oil components from PE pyrolysis at 740°C	(Kaminsky et al., 2004)	Benzene, pyrene, toluene, indane
Separation of gas components from PP pyrolysis at 760°C	(Kaminsky et al., 2004)	Methane, ethylene, ethane, propylene
Separation of light oil components from PP pyrolysis at 740°C	(Kaminsky et al., 2004)	Benzene, toluene, naphthalene
Pyrolysis of oil components from PS pyrolysis at 500°C	(Onwudili et al., 2009)	Ethylbenzene, toluene, cumene, triphenylbenzene

MPW can be directly pyrolyzed or sorted into the plastic fractions that compose it. The pyrolysis products are gas and/or oil mixtures, which can be fractionated through separation sequences. For this illustrative case, gas or oil streams are sent to separation to be split into all their components. However, if a higher level of detail is required, the model is flexible enough to consider individual separations as independent transformation processes that can be selected individually.

The processes characterization is done considering the references that provide more accurate data in terms of gas/oil fractions and product distributions. Table 10.2 shows the selected processes, the source and the products they reported. For the sake of simplicity, minor products that are present in a mass fraction lower than 5% are eliminated.

Despite the fact that MPW can be sorted into polyethylene (PE), polystyrene (PS), polyethylene terephthalate (PET) and polypropylene (PP), the pyrolysis of PET is left outside of the study since several works show that the gas fraction contains mainly CO₂ (Williams and Williams, 1999) so it is left for its energy valorization through incineration. A similar consideration is done with gas and oil fractions resulting from pyrolysis: as their value as final products is uncertain (Honus et al., 2016), when not separated into their compounds they can only be profitable if they are incinerated. All costs are updated to 2019 with GDP deflators (The World Bank, 2019). Sorting cost is taken from Brandrup et al. (1996). For the other transformation processes, flowsheets are built according to standard heuristics (Seider et al., n.d.) and simulated (Aspen Plus) to obtain the sizing parameters and energy consumptions. Unitary cost estimations are calculated by gathering CAPEX and OPEX from Aspen Process Economic Analyzer, and dividing annualized capital costs and operating costs by the maximum annual production according to capacity. The resulting cost parameters are summarized in Table 10.3. Due to the low technology readiness level of the pyrolysis processes, costs are considered as a main source of uncertainty. 100 cost scenarios were defined using Monte Carlo sampling within a range of $\pm 20\%$ with respect to the calculated value. All costs are updated to 2019 with GDP deflators (The World Bank, 2019).

Table 10.3. Unitary capital and operating cost for technologies.

Process	Unitary capital cost (€/t)	Unitary operating cost (€/t)
Sorting of Mixed Plastic Waste (MPS)		314.56
Pyrolysis of MPS	10.90	63.54
Pyrolysis of PE at 1000°C	11.54	142.31
Pyrolysis of PE at 740°C	11.39	124.20
Pyrolysis of PP at 760°C	11.41	125.57
Pyrolysis of PS at 425°C	10.88	60.78
Separation of gas from PE pyrolysis at 1000°C	17.43	43.87
Separation of gas from PE pyrolysis at 740°C	68.07	271.29
Separation of light oil from PE pyrolysis at 740°C	11.11	55.92
Separation of gas from PP pyrolysis at 760°C	22.27	86.34
Separation of light oil from PP pyrolysis at 740°C	7.51	35.92
Separation of oil from PS pyrolysis at 500°C	22.15	82.84

Table 10.4 shows demands for the bulk chemicals considered as products and outsourcing possibilities, which are scaled from total European production (Eurostat - European Commission, 2018) to satisfy the needs of the industry associated to a population of 5 million people. In comparison, demands for fuels like methane or hydrogen are several orders of magnitude higher and would shift the solution to its production. Thus, it is considered that any produced amount can be sold. A similar consideration is done for specialties when amounts produced are low and demand is uncertain. For the sake of comparability when solving the multi-objective model for profit maximization and environmental impact minimization, the constraint on demand satisfaction (Eq. (10.2)) is modified to be an equality.

Table 10.4. Yearly production for bulk chemicals and escalated demands.

Bulk chemical	Total production (Mt/y) (Eurostat - European Commission, 2018)	Escalated demand (t/h)	Price (€/t)
1,3-Butadiene	2994	7.13	655.86
Benzene	6251	14.89	596.91
Butene	2101	5.00	638.00
Cumene	1928	4.59	553.68
Ethylbenzene	4186	9.97	479.85
Ethylene	17885	42.59	798.60
Naphthalene	4447	10.59	547.32
Propylene	12846	30.59	699.51
Styrene	4918	11.71	910.49
Toluene	1239	2.95	555.16

The available end-of-life alternatives include landfilling of plastic waste and incineration with energy recovery for all the compounds. Mechanical recycling is not considered because of the lack of consistent data regarding its application. Cost for landfilling is retrieved from Baldasano, Gassó, and Pérez (2003) and updated to 2019. Cost for incineration is also updated from values found literature (Gradus et al., 2017), while credits are calculated by the savings on natural gas by using lower heating values of the compounds (ECN.TNO, 2019; Hydrogen tools, 2019). Values are shown in Table 10.5.

Table 10.5. Costs for landfilling and incinerating products.

Compound	Landfilling cost (€/t)	Incineration cost – credits (€/t)
MPS	97.53	-321.79
PE waste	97.53	-364.92
PP waste	97.53	-364.92
PS waste	97.53	-326.51

10. Synthesis of circular economy networks

PET waste	97.53	-115.80
Gas from pyrolysis of MPS	-	-395.41
Oil from pyrolysis of MPS	-	-312.44
Gas from pyrolysis of PE at 1000°C	-	-395.41
Gas from pyrolysis of PE at 740°C	-	-395.41
Oil from pyrolysis of PE at 740°C	-	-312.44
Gas from pyrolysis of PP at 760°C	-	-395.41
Oil from pyrolysis of PP at 760°C	-	-312.44
Oil from pyrolysis of PS at 425°C	-	-312.44
Hydrogen	-	-1211.36
Methane	-	-398.09
Ethylene	-	-398.82
Ethane	-	-405.50
Propylene	-	-383.23
Propane	-	-388.60
Butene	-	-378.03
Butadiene	-	-369.98
Butane	-	-377.32
Benzene	-	-320.37
Toluene	-	-325.05
Ethylbenzene	-	-328.95
Styrene	-	-327.07
Cumene	-	-332.06
Indane	-	-312.44
Naphtalene	-	-312.44
Pyrene	-	-312.44
Triphenylbenzene	-	-312.44

Environmental impacts for transformation processes are quantified by performing gate-to-gate life cycle assessments following ReCiPe method (**Table 10.6**). Inventories are built gathering material and energy balances information from flowsheet simulations, considering a ton of material processed as functional unit. The entries beyond the boundaries of the system were retrieved from the Ecoinvent database v3.4, accessed via SimaPro.

Table 10.6. Endpoint indicators per ton of material processed.

Process	Human health (DALY)	Ecosystems (species-yr)	Resources (USD2013)
Sorting of Mixed Plastic Waste (MPS)	2.68E-04	4.10E-07	2.6
Pyrolysis of MPS	8.50E-05	2.34E-07	9.7
Pyrolysis of PE at 1000°C	4.22E-04	1.16E-06	48.3
Pyrolysis of PE at 740°C	1.12E-03	2.60E-06	75.7
Pyrolysis of PP at 760°C	2.34E-03	5.37E-06	119.8
Pyrolysis of PS at 425°C	8.34E-04	1.97E-06	62.8
Separation of gas from PE pyrolysis at 1000°C	3.44E-04	9.46E-07	39.5
Separation of gas from PE pyrolysis at 740°C	3.50E-04	9.62E-07	40.1
Separation of light oil from PE pyrolysis at 740°C	7.32E-05	2.01E-07	8.4
Separation of gas from PP pyrolysis at 760°C	1.00E-03	2.33E-06	64.0
Separation of light oil from PP pyrolysis at 740°C	5.58E-04	1.31E-06	42.2
Separation of oil from PS pyrolysis at 500°C	1.00E-03	2.33E-06	64.0

10.6. Results

The model is implemented in GAMS 27.3.0 and solved using CPLEX 12.9 on an Intel i5-8250U CPU @1.6 GHz machine. The model features 7807 equations, 17321 continuous variables and 14 discrete variables. The average time to solve a point of the Pareto curve, consisting of 100 cost scenarios for a certain environmental impact (ϵ -constraint method), is 1.39s. This leads to a total computing time of 55.74 s required to solve all the scenarios needed to compile the results presented below.

First, profit is optimized, resulting in the optimal network design represented in Figure 10.2. Available amounts of MPW, PE and PP waste are acquired to be transformed. The high cost of PS waste and the impossibility of revalorizing PET apart from incineration are underlined.

MPW is directly pyrolyzed, which produces a wider range of gas and oil products than sorting it before pyrolyzing the different plastics. However, this last option is found to be less profitable in comparison to the high costs of separation. Due to this, the oil fraction is sent to incineration to valorize it into energy. As for PE and PP, they both are pyrolyzed and the resulting gas and oil streams are separated into their components and sold or incinerated.

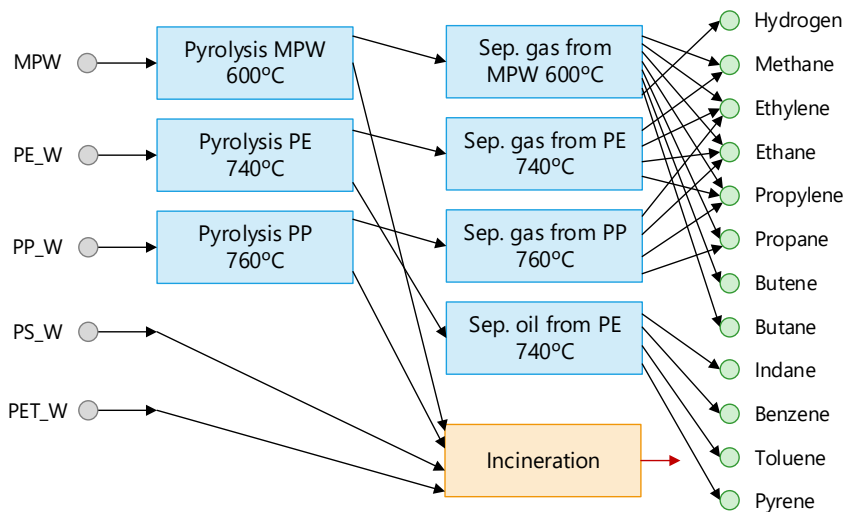

Figure 10.2. Optimal network solution for profit maximization.

Figure 10.3 shows the cost breakdown for this solution. After balancing costs and incomes, expected profit can reach up to 1062.61 €/t. While hydrocarbon recovery from plastic waste is profitable, there is a clear gap between waste transformation yields and hydrocarbon demand. This difference leads to high outsourcing requirements, in order to cover the demand, stressing the need to foster waste collection systems. Without considering outsourced requirements, more than half of the cost (57%) is due to the waste purchase. Waste treatment leads to a 27% of the costs and a 52% of revenues, including products and by-products, while the incineration of the oil from MPW pyrolysis entails a 17% of the costs and a 48% of income.

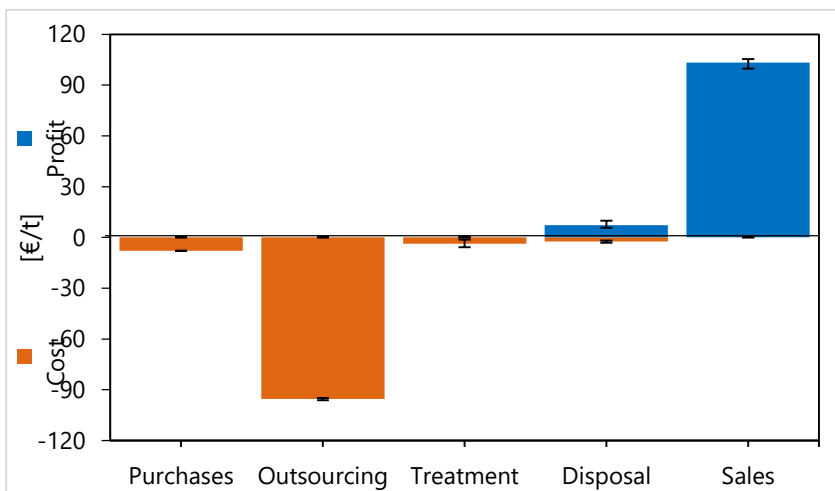

Figure 10.3. Cost and profit breakdown.

Figure 10.4 compares the cost breakdown of chemicals produced from waste recovery in front of their market price. The margins between total production cost and selling price are in the range of 3.9% for toluene to 9.4% for benzene. This reveals that substantial research needs to be performed to improve their competitiveness, since currently the main advantage of the selected network comes from avoiding the cost of treating waste at end-of-life alternatives. In this sense, it should be taken into account that the required technologies are still under development, so performance and costs may vary once they become more mature, for example by means of process integration, which will lead to improve these margins.

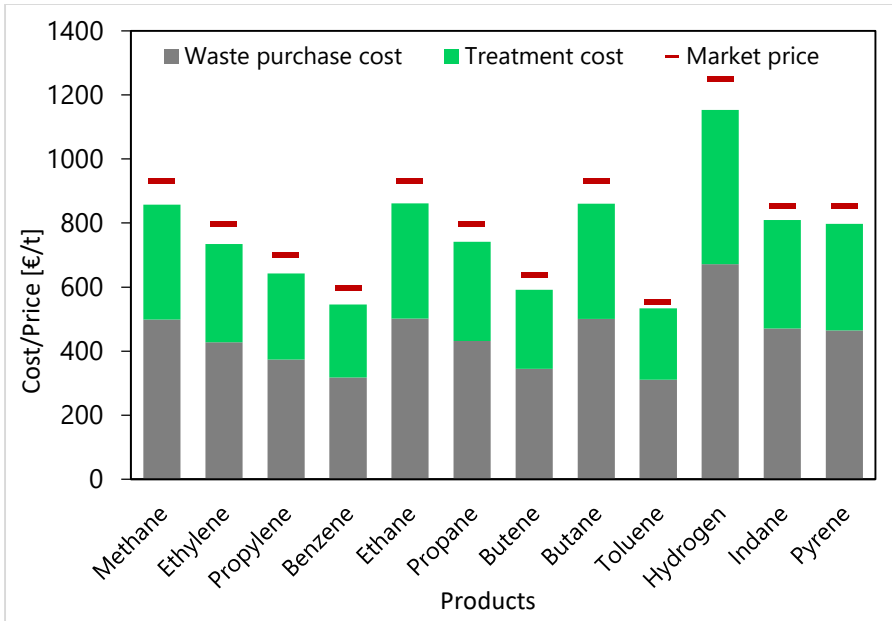

Figure 10.4. Cost of chemicals from waste recovery vs market price.

This maximum profit solution corresponds to one of the anchor points in the Pareto frontier represented in **Figure 10.6**, where the squares represent the trade-off between profits and endpoint environmental impacts. Different colors are used for the diverse network designs found. Triangles correspond to the same analysis banning treatment technologies, so that waste can only be landfilled or incinerated and all product demands are satisfied by outsourcing. The network configurations of the different solutions provided for the Pareto assessment can be consulted in Figure 10.5.

The comparison between the two approaches underlines the need to move towards the introduction of recycling technologies, as traditional hydrocarbon production and end-of-life treatment (i.e. production of hydrocarbons from naphtha and disposing/incinerating plastic waste) are always dominated, disregarding which is the economic or environmental objective/perspective used. However, there is still a lot of work to be done with regard to the recycling processes design and integration. This is due to the fact that the most environmentally-friendly processes are found to be the ones with a higher energy consumption, emphasizing the need to design more efficient processes (e.g.: implementing energy integration), which were

not included in the flowsheet simulation for the sake of comparison. For example, this is the case of polyethylene pyrolysis at 1000°C, which exhibits a lower environmental impact due to its high conversion of waste to gas, which increases its hydrocarbon production in spite of the high energy consumption required to reach such temperatures. Error bars denote how significant is the effect of the uncertainty in the costs and yields of the different considered technologies, which propagates to the final results.

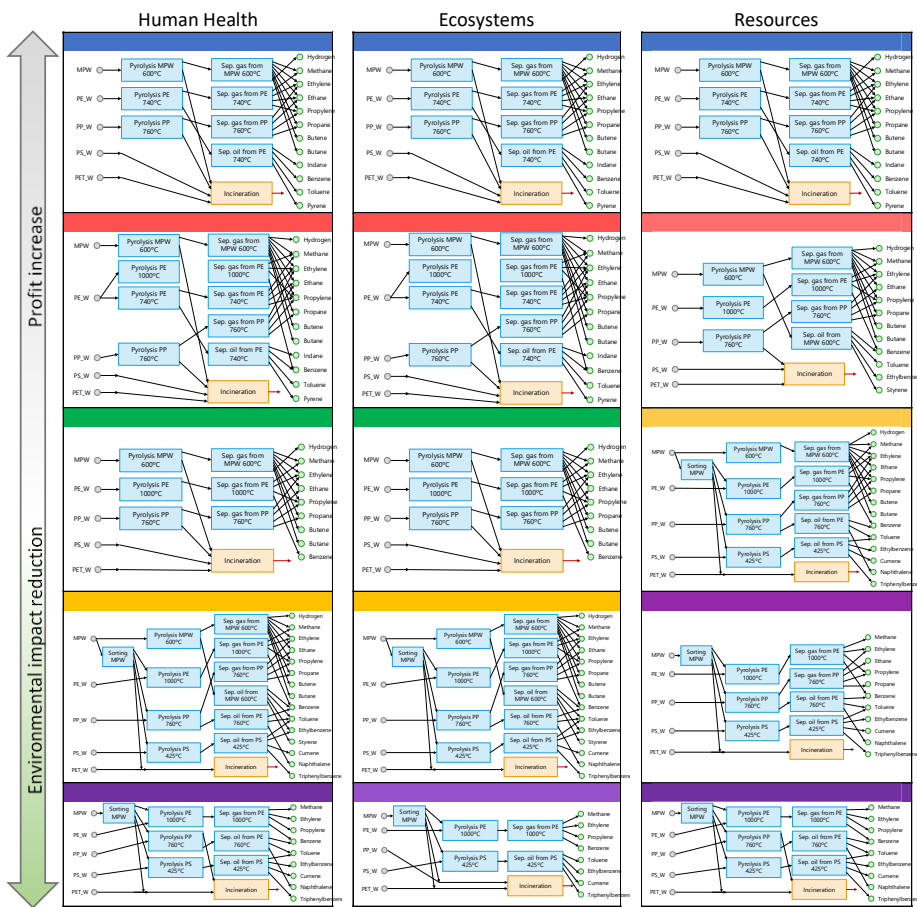
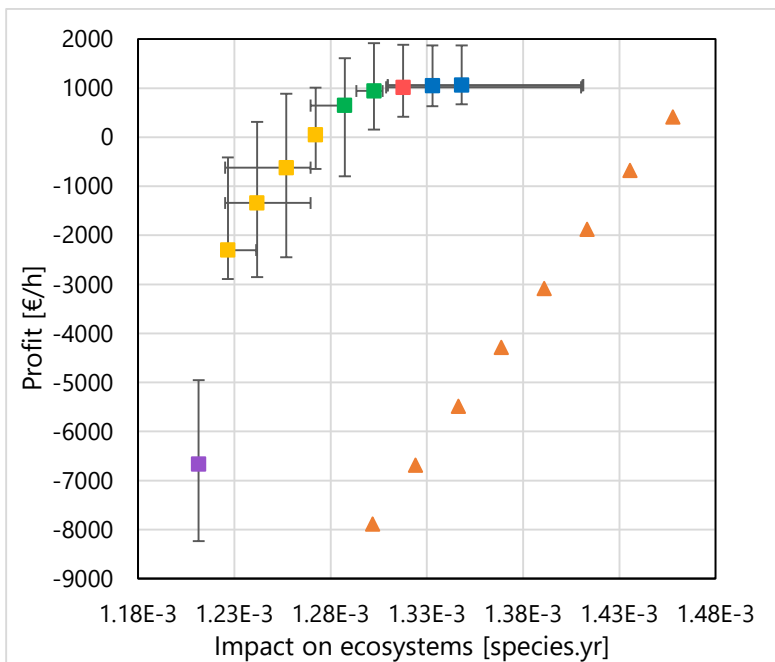
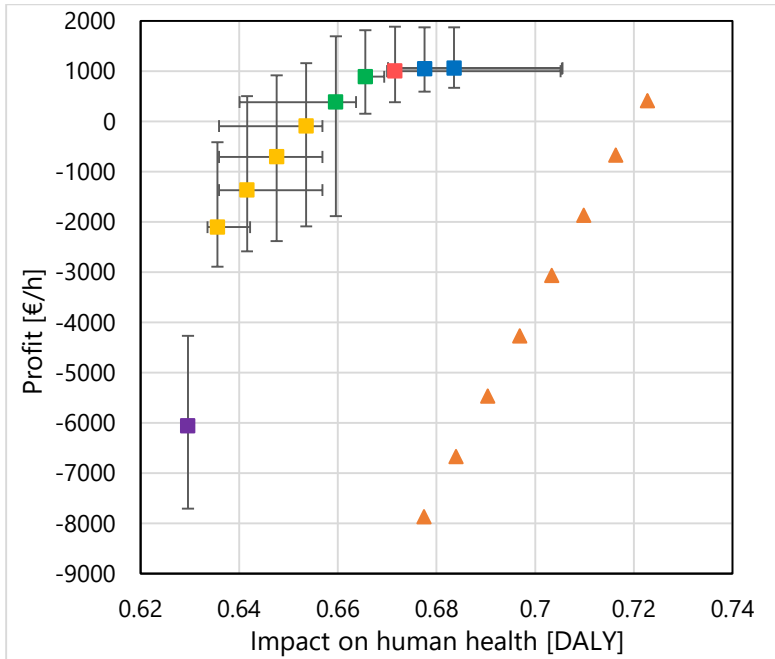

Figure 10.5. Network configurations for the solutions in the Pareto fronts.

10. Synthesis of circular economy networks



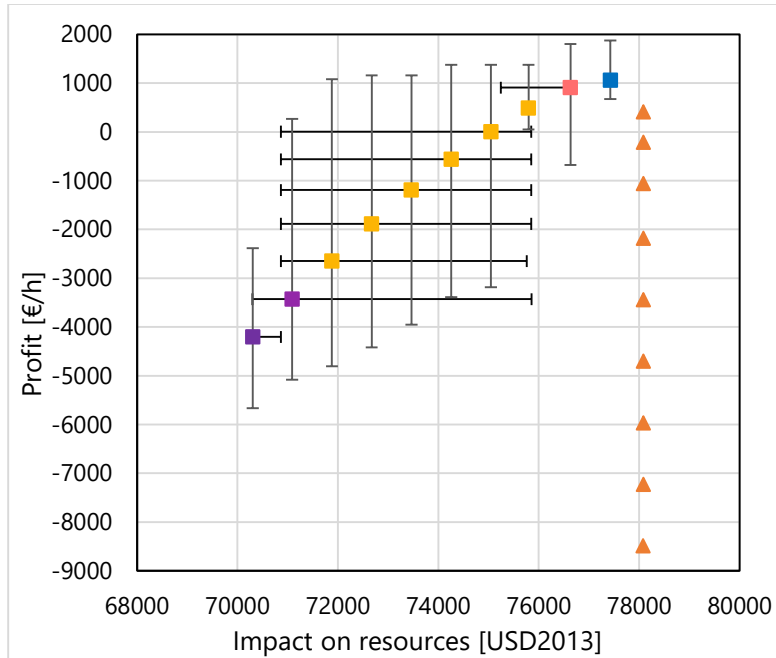

Figure 10.6. Pareto curves for the trade-off between profit and environmental endpoint impacts on a. human health, b. ecosystems and c. resources. Squares represent the results obtained considering transformation technologies, while triangles represent the results without considering any transformation at all. Colors represent different network designs.

Figure 10.6.a shows the trade-off between profit and impact on human resources. From the anchor point of maximum profit to the one of minimum impact on human health, the latter can be reduced up to an 8.6% with a big drop of 6.7 times in profit, thus becoming negative. From a technical point of view, the reduction in the impact is achieved first by switching from pyrolysis of PE at 740°C to 1000°C, and consequently improving the associated separation process (from solutions in blue to red and green); second by adding the sorting MPS and pyrolyzing plastics separately in a more environmentally efficient way; and third by including PS pyrolysis (from green to yellow). Finally, a major effect can be observed in the solution marked in purple, associated to the elimination of MPW pyrolysis, which results to be less environmentally friendly because of the high number of produced compounds

that need to be separated (energy consuming process). Similar effects are appreciated when considering the impacts on ecosystems quality and resources conservation, with improvements on impact scores of 8.1% and 7.2% respectively, associated to major profit drops (7.3 and 5.0 times, respectively).

These results show how transformation processes can enhance industrial symbiosis potential beyond the conceptual limits of conventional EIPs: efforts should be aimed at recovering valuable materials from waste, but also introducing the economic performance of the network decisions, that should be complemented with environmental assessment via LCA to fully understand the effect of introducing waste-to-resource technologies.

10.7. Remarks

This section presents an optimization model for the screening of waste-to-resource technologies during the design of industrial symbiosis networks. Departing from a model based on previous knowledge in the literature, an optimization model has been built by introducing the concepts inherent to industrial symbiosis network optimization (i.e. waste acquisition, outsourced materials and end-of-life alternatives for waste). The resulting MILP model is formulated as a superstructure able to represent how the demand of bulk chemicals can be satisfied from traditional processes or from different waste transformation routes. Waste treatment can be done using open-cycle end-of-life alternatives (e.g. landfill or incineration) or through their circular counterparts (e.g. plastic pyrolysis to recover its monomers and reintroduce them in the life cycle).

The optimization model presented not only allows the identification of the most promising processing networks for waste recovery by selecting the most favorable waste transformation processes among a list of potential alternatives, but it also enables system debottlenecking. Thus, it recognizes the weakest processes in the network and unveiling those that perform worst according to the different adopted criteria and the potential scenarios considered.

The model is formulated to be flexible enough to address the different challenges that poses the design and management of industrial symbiosis networks, including the consideration of the effects of different sources of

data uncertainty (e.g. in the cost of applying different technologies or in the yields of the required transformation processes) and/or its solution under different optimization criteria (e.g. profit maximization and environmental impact minimization).

The capabilities of the model have been illustrated through its application to a case study on hydrocarbon recovery from waste plastic pyrolysis. In this concern, the model becomes a valuable tool for the assessment of processes with a low technology readiness level, allowing the identification of aspects that require further development efforts (e.g.: energy integration, PS reuse options, etc.).

From a general perspective, the model identifies the optimal network to be transitioned to. Private companies could spot business opportunities in the waste transformation processes. Scientists and technology developers can identify which processes need to be further investigated (i.e. designing catalysis that improve its performance or integrating it to reduce energy consumption). Besides, policy makers can use the model to identify processes which are environmentally promising but not competitive from an economical point of view and incentivize them to achieve impact reduction legal requirements, or introduce additional economic incentives to increase global environmental performance.

In this sense, future work will include the analysis of the effect on the decisions of simultaneously considering the points of view of all these different participating stakeholders, through the application of game theory concepts and tools.

Synthesis of flexible processes with material recovery opportunities

11.1. Introduction

Conceptual models are required for the systematic synthesis of processes in particular for recovery opportunities. State-task network (STN, (Kondili et al., 1993)) and state-equipment network (SEN, (Smith, 1996)) are two process representations commonly used as a base for the superstructure representation required to address the conventional problem of process synthesis. While the STN representation is easier to formulate, the SEN representation is more suitable for modeling equipment networks, as it reduces the number of process nodes and prevents zero-flow singularities (Chen and Grossmann, 2017).

However, both conceptual models generally rely on the premise that product specifications are narrowly bounded (i.e. final products are single-component with a defined purity), and fail to consider other decisions that would affect the final result (i.e. solutions in which intermediate products or mixtures may be sold or recycled into the process). This problem becomes crucial in the synthesis of processes addressing the circular economy paradigm, where material recovery alternatives are numerous and diverse. Hence, this chapter presents a novel modeling approach for the optimal synthesis of processes with flexible product composition, including equipment activation/deactivation, and the possibility of selling/recycling mixed streams. It aims at providing a more detailed synthesis of the processes selected in Chapter 10 by considering joint process and product synthesis.

11. Synthesis of flexible processes with material recovery opportunities

As tested in the previous case study, processes for the chemical upgrading and recycling of polymers, such as the pyrolysis of plastics, lead to hydrocarbon mixtures similar to those from crude oil cracking but with different compositions. The two main alternatives for these products include their use as fuels (i.e. waste-to-energy, Honus et al., 2016) and their separation to recover the monomers that can be used to produce new chemicals or polymers (Hong and Chen, 2017), which results in a more efficient use of valuable resources and may increase incentives for recycling and closing material loops.

11.2. Problem statement

The following problem statement complements the one in Chapter 10 to address the points defined in section 4.1. It can be stated as follows: given is a set of raw materials (usually subproducts/waste) and process alternatives (equipment and tasks), the objective is to find the path to convert these materials into the most valuable resources, taking into account current market requirements.

In order to achieve this objective, these elements have to be represented in a flexible superstructure that considers different alternatives for pure or mixed products (i.e. selling or recycling) and also different flowsheeting alternatives and equipment design.

11.3. Joint process and product synthesis

The proposed method to address the synthesis problem consists of a three-step approach based on the work by Yeomans and Grossmann (1999): superstructure representation, modeling (Generalized Disjunctive Programming - GDP), and model resolution. This approach integrates product and product, as opposed to state of the art on process design.

11.3.1. Superstructure representation

Separation processes are generally modeled considering that the inlet is separated in all the products that integrate it. STN leads to easier problem for-

mulations, whereas SEN is more easily solved since it prevents zero-flow singularities (Chen and Grossmann, 2017). However, the synthesis of waste-to-resource processes requires a more flexible superstructure representation of separation sequences, including the activation and deactivation of equipment (as in STN) and the flexible assignment of tasks to equipment (as in SEN). This is done through the implementation of the most general form of SEN network (Yeomans and Grossmann, 1999) which does not avoid zero-flow singularities.

A generic example of superstructure representation of a process flowsheet including flexible product composition and material recovery is shown in Figure 11.1.

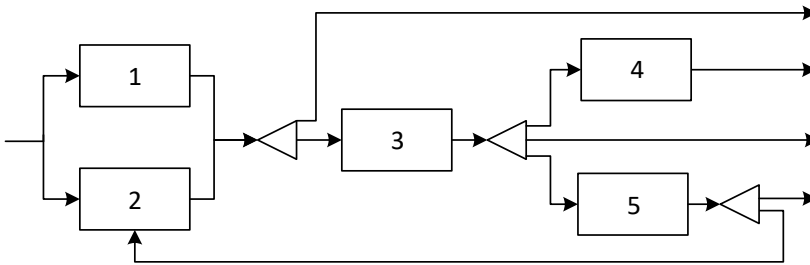

Figure 11.1. Example of superstructure for joint product and process synthesis.

11.3.2. GDP formulation

The superstructure defined in the previous step is now modeled and formulated using GDP (Raman and Grossmann, 1994). Let $j \in J$ define the set of equipment in the superstructure and $k \in I_j$ the set of tasks that can be performed in each equipment j . x_j and z_{jk} denote the continuous variables representing the operating conditions of the system, while the Boolean variables Y_j and W_{jk} represent whether equipment j is active and whether task k is assigned to it, respectively. The resulting formulation is as follows:

11. Synthesis of flexible processes with material recovery opportunities

$$\min z = \sum_{j \in J} c_j + f(x_j, z_{jk}) \quad (11.1)$$

$$\text{s. t. } f(x_j, z_{jk}) \leq 0 \quad (11.2)$$

$$\left[\begin{array}{c} \vee \\ k \in I_j \end{array} \left[\begin{array}{c} Y_j \\ W_{jk} \\ f_{jk}(x_j, z_{jk}) \leq 0 \\ c_j = \gamma_{jk} \end{array} \right] \right] \vee \left[\begin{array}{c} \neg Y_j \\ x_j = z_{jk} = 0 \\ c_j = 0 \end{array} \right] \quad \forall j \in J \quad (11.3)$$

$$\Omega(W_{jk}) = True \quad (11.4)$$

$$Y_j \in \{True, False\} \quad \forall j \in J \quad (11.5)$$

$$W_{jk} \in \{True, False\} \quad \forall j \in J, k \in I_j \quad (11.6)$$

The objective function to be minimized (Eq. 1) includes the fixed cost associated to the active equipment units and a function of the continuous variables (i.e. variable costs and income from selling the products). Algebraic constraints in Eq. (2) are equalities and inequalities that must be satisfied for any realization of the discrete variables, typically including mass balances that define the connections among the nodes of the superstructure. On the other hand, constraints that are inherent to equipment activation and task assignments are modeled in nested disjunctions. The external ones are based on the existence of equipment j , while the internal ones define task selection. Thus, if equipment j is active ($Y_j = True$) and task k is selected ($W_{jk} = True$), constraints $f_{jk}(x_j, z_{jk}) \leq 0$ are applied and the related fix costs are considered in the objective function $c_j = \gamma_{jk}$. Conversely, if equipment j is not selected ($Y_j = False$) continuous variables and fix costs are set to 0. Finally, logical constraints among the nodes of the superstructure are given by $\Omega(W_{jk})$ (Eq. (4)). These include enforcements of consecutive tasks in order to meet recipe-based constraints.

11.3.3. Model resolution

The model is implemented in Pyomo and solved with DICOPT after its reformulation to a MINLP using the Big M method.

11.4. Case study

In Chapter 10, the pyrolysis of polyethylene at 1000°C was found to be one of the key processes to improve the environmental performance of the network. Hence, to illustrate the proposed synthesis approach, it has been applied on this process. As in Chapter 6, experimental data from the literature is used to model the outlet from the pyrolysis furnace. Kannan et al. (2014) reported high conversions (>99%) of the polymer to gas when operating at 1000°C, leading to outlet compositions of: 5% methane, 46% ethylene, 18% propylene, 3% propyne, 2% 1-butene, 13% 1,3-butadiene and 13% benzene. The main objective is to identify to which extent the gas resulting from the pyrolysis of polyethylene at such conditions should be separated into its compounds, according to the cost of separation and the market price for pure or mixed compounds. The model should also identify if any of the streams could be used as fuel to satisfy the energy requirements of the furnace used to maintain the operating conditions.

11.5. Results

In this section, the results for the synthesis of the case study are presented following the methodology described in section 11.3.

11.5.1. Superstructure representation

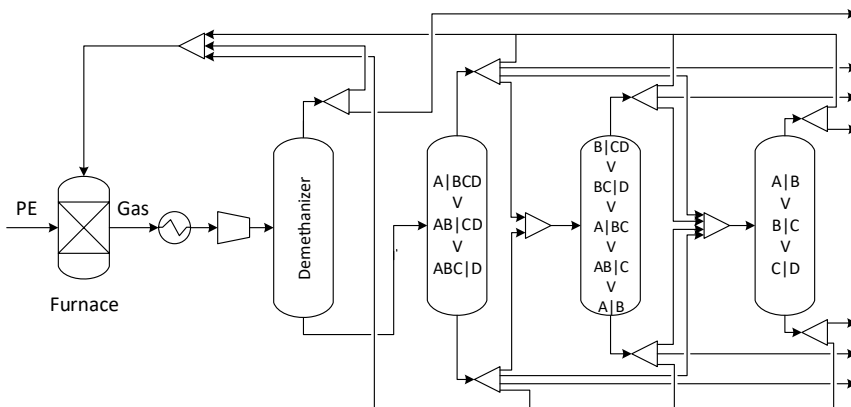

Figure 11.2. Superstructure representation of the process.

Figure 11.2 shows the superstructure for the proposed case study. The outlet of the pyrolysis reactor is cooled and compressed to enter the distillation sequence where the different hydrocarbons may be recovered. For the sake of simplicity and due to the different boiling point of methane compared to the rest, the stream is demethanized before entering the distillation sequence. After this step, a four component mixture distillation train is considered, in order to split the inlet into its fractions of ethylene (A), propylene (B), 1,3-butadiene (C) and benzene (D). Propyne and 1-butene are recovered with 1,3-butadiene since their low concentration would not justify two extra separation stages. The first column considers the three possible tasks for the first level separation of the four-component mixture. The second one includes the three-component separations of the streams resulting from the previous column, plus the separation A|B in case AB|CD is selected in column one. Finally, column 3 can perform the two-component separation of outlet streams from column two. All three distillation columns can be active or inactive, but the existence of one implies that the previous ones need to exist. All outlet streams can be introduced to the next separation level, sold as final product, or reused in the process as fuel for the furnace.

11.5.2. Model formulation

The model is formulated following the GDP described in section 11.3.2 with the following considerations:

- The objective function (Eq. (11.7)) is the profit maximization taking into account: the income for product sales (proportional to its purity), fix and variable costs for the active distillation columns, and fresh fuel savings.
- $f(x_j, z_{jk}) \leq 0$ include the mass balances (Eqs. (11.8,11.16)) at the nodes of the superstructure (e.g. the distillate of column one can be sold as a product, used as fuel at the furnace or go to column two if AB or ABC mixes are produced).
- $f_{jk}(x_j, z_{jk}) \leq 0$ represent the equations that depend on the column activation and task selection (e.g. mass balance of the distillation columns or reflux ration calculation in Eq. (11.17)).

- $\Omega(W_{jk})$ is translated to Eqs. (11.18-11.25), which denote the logical constraints that should be enforced (e.g. column 3 can only be active if column 1 and 2 are also active).
- Objective function

$$\max z = \sum_{j \in COL} \left(\sum_{i \in C} \delta_i (F_{ij}^{DPP} + F_{ij}^{BPP}) - \mu_j - \sum_{i \in C} \beta_j F_{ij}^F \right) \quad (11.7)$$

- Mass balances

$$\text{s.t.} \quad F_{i1}^F = x_i^{FEED} F^{FEED} \quad (11.8)$$

$$F_{i1}^D = FC_{i12}^D + FC_{i13}^D + F_{i1}^{DF} + F_{i1}^{DPP} \quad (11.9)$$

$$F_{i1}^B = FC_{i12}^B + FC_{i13}^B + F_{i1}^{BF} + F_{i1}^{BPP} \quad (11.10)$$

$$F_{i2}^F = FC_{i12}^D + FC_{i12}^B \quad (11.11)$$

$$F_{i2}^D = FC_{i23}^D + F_{i2}^{DF} + F_{i2}^{DPP} \quad (11.12)$$

$$F_{i2}^B = FC_{i23}^B + F_{i2}^{BF} + F_{i2}^{BPP} \quad (11.13)$$

$$F_{i3}^F = FC_{i13}^D + FC_{i23}^D + FC_{i13}^B + FC_{i23}^B \quad (11.14)$$

$$F_{i3}^D = F_{i3}^{DF} + F_{i3}^{DPP} \quad (11.15)$$

$$F_{i3}^B = F_{i3}^{BF} + F_{i3}^{BPP} \quad (11.16)$$

- Disjunction

$$\left[\begin{array}{l} Y_j \\ \vee \\ Y_{jk} \end{array} \left[\begin{array}{l} F_{ij}^n = F_{ijk}^n \quad n \in \{F, D, B\}, i \in C_k \\ x_{ij}^n = x_{ijk}^n \quad n \in \{F, D, B\}, i \in C_k \\ FT_j^n = \sum_{i \in C_k} F_{ijk}^n \quad n \in \{F, D, B\} \\ F_{ijk}^n = x_{ijk}^n FT_j^n \quad n \in \{F, D, B\}, i \in C_k \\ \sum_{i \in C_k} x_{ijk}^n = 1 \quad n \in \{F, D, B\} \\ F_{ijk}^D + F_{ijk}^B = F_{ijk}^F \quad i \in C_k \\ F_{ijk}^D = \rho_i F_{ijk}^F \quad i \in C_k \\ F_{ijk}^B = (1 - \rho_i) F_{ijk}^F \quad i \in C_k \\ \beta_j, \mu_j = \text{specified}_{value} \\ RR_j = f(\rho_j) \\ NT_j = f(\rho_j) \\ D_j = \xi_j \cdot F^{FEED} \\ V_j = (RR_j + 1) \cdot D_j \\ C_j = NT_j \cdot \theta_j \cdot V_j \\ \in COL \end{array} \right] \vee \left[\begin{array}{l} \neg Y_j \\ F_{ij}^n = 0 \quad n \in \{F, D, B\}, i \in C_k \\ F_{ijk}^n = 0 \quad n \in \{F, D, B\}, i \in C_k, k \\ FT_j^n = 0 \quad n \in \{F, D, B\} \\ x_{ij}^n = 0 \quad n \in \{F, D, B\}, i \in C_k \\ x_{ijk}^n = 0 \quad n \in \{F, D, B\}, i \in C_k, k \\ \beta_j, \mu_j = 0 \end{array} \right] \right] \quad (11.17)$$

- Logical constraints

$$Y_{2,4} \Rightarrow Y_{1,1} \quad (B|CD \Rightarrow A|BCD) \quad (11.18)$$

$$Y_{2,5} \Rightarrow Y_{1,1} \quad (BC|D \Rightarrow A|BCD) \quad (11.19)$$

$$Y_{2,6} \Rightarrow Y_{1,3} \quad (A|BC \Rightarrow ABC|D) \quad (11.20)$$

$$Y_{2,7} \Rightarrow Y_{1,3} \quad (AB|C \Rightarrow ABC|D) \quad (11.21)$$

$$Y_{2,8} \Rightarrow Y_{1,2} \quad (A|B \Rightarrow AB|CD) \quad (11.22)$$

$$Y_{3,9} \Rightarrow Y_{2,7} \quad (A|B \Rightarrow AB|C) \quad (11.23)$$

$$Y_{3,10} \Rightarrow Y_{2,5} \vee Y_{2,6} \quad (B|C \Rightarrow BC|D \vee A|BC) \quad (11.24)$$

$$Y_{3,11} \Rightarrow Y_{2,4} \vee Y_{1,2} \quad (C|D \Rightarrow B|CD \vee AB|CD) \quad (11.25)$$

11.5.3. Model resolution

The model is implemented in Pyomo and solved with DICOPT after its reformulation to a MINLP using the Big M method. The MINLP involves 36 binary variables, 2353 continuous variables and 4280 constraints and was solved in 34 CPUs on an Intel Xeon processor operating at 2.20GHz.

Figure 11.3 depicts the optimal solution for the flowsheet design for the material recovery from polyethylene pyrolysis. In this particular case all units were selected, so zero-flow singularities are not present.

The methane from the gas demethanization is sold, and the bottoms are sent to column 1. Here, task A|BCD is active, leading to the production of ethylene. Likewise, propylene and 1,3-butadiene are recovered in the distillates of columns 2 and 3, respectively. Thus, direct distillation was found to be the optimal option. Ethylene, propylene and benzene are sold, while 1,3-butadiene is burned as fuel at the furnace due to its low purity.

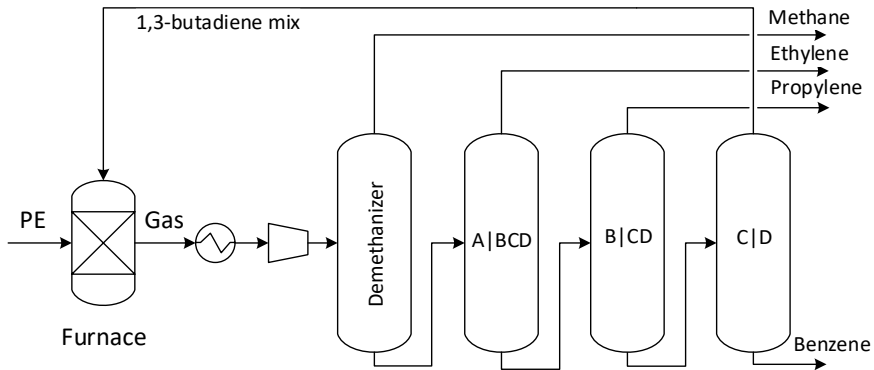

Figure 11.3. Optimal flowsheet design for the material recover from polyethylene pyrolysis.

11.6. Remarks

This chapter has introduced a general framework to represent, model and solve the joint product and process synthesis problems resulting from the consideration of waste-to-resource transformations. To achieve this objective, the work has extended the three-step method proposed by Yeomans and Grossmann (1999). First, the model is represented through the generalized version of a SEN, including task selection and equipment activation and deactivation to address the singularities of processes for material recovery. Second, the model is formulated as a GDP. Finally, the model is transformed into a MINLP through the Big M method and solved in Pyomo/DICOPT. The capabilities for the joint synthesis of processes and products of the model have been tested through its application to the synthesis of a flowsheet for the recovery of hydrocarbons from the pyrolysis of polyethylene. The proposed methodology has been proven useful to identify the optimal extent of separation and the most economically profitable products in a systematic way. Moreover, the consideration of joint product and process synthesis is essential to identify the most economically profitable products and their optimal separation extents in a systematic way. Future work will include the implementation of decomposition techniques to address the cases which present zero-flow singularities.

Part V: Conclusions and outlook

Conclusions and future work

This thesis is aimed at providing models and tools to support the decision-making while implementing circular economy principles in process systems, by targeting and identifying opportunities and, particularly, by closing material cycles through waste-to-resource technologies. The objectives posed in Chapter 1 have been successfully addressed and the work developed has been discussed along the different chapters.

As a case study, the challenge of processing plastic waste has been tackled from this circular economy perspective. Different approaches to the chemical recycling of plastics have been used to illustrate the tools proposed, enlightening the potential of closing material loops in a systematic way.

12.1. Main contributions

This Thesis has addressed the development of some methodological and practical contributions. From the methodological point of view, a framework for the implementation of circular economy principles at the process industry has been presented (Chapter 4). It supports the decision-making of closing resource groups through waste-to-resource technologies and the resulting alternative network configurations.

- First, a systematic procedure to characterize technologies has been introduced (Chapter 5) to facilitate the comparison of traditional and novel technologies. With the aim of standardizing data from different sources, process simulations have been used to upscale data from lab scale found in the literature. Economic performance, LCA and TRL are the chosen indicators for a fair comparison.

12. Conclusions and future work

- The need for a structured classification of the data regarding these processes has led to the extension of an already existing ontological framework to include the criteria mentioned above.
- Chemical targeting has been introduced as a method to identify the potential to recover material from known sources of waste, based on market demand. An extended version of the targeting approach has been developed to include waste transformation and resource outsourcing, so a new dimension of potential destinations for waste are explored for the implementation of material recovery.

After these previous steps, some of these elements have been linked in order to address the problem of the optimal design of material exchange networks from a multilevel perspective. This is a first step in the direction of creating a complete holistic approach for the integrated synthesis and design of networks and processes.

- At the strategic level, a method for screening waste-to-resource technologies has been presented, which allows alternative configurations to be assessed and ranked according to economic and environmental criteria. Hence, the best alternatives can be selected and the worst discarded.
- At the tactical level, an optimization model for the detailed synthesis of individual processes selected in the resulting network is proposed. The synthesis of waste-to-resource applications differs from traditional synthesis approaches by providing a flexible product specification. Thus, the consideration of joint product and process synthesis has been found essential to identify the most economically profitable products and their optimal separation extents in a systematic way.

The developed methodologies have been validated and illustrated through their application to different cases. In particular, the case of the chemical recycling of plastic waste has been extensively used in this Thesis, since it also led to interesting practical findings.

- A preliminary study on the recovery of ethylene through the pyrolysis of polyethylene has been performed. Recycled ethylene is found to perform economically and environmentally better than ethylene produced by the business-as-usual method. Regarding end-of-life alternatives for waste polyethylene, pyrolysis is more competitive than landfill and incineration due to the credits assigned for the recovery of ethylene and

other valuable products. Thus, pyrolysis is revealed as a promising technology to close the loop in the ethylene sector.

- When comparing different pyrolysis technologies, due to higher temperatures give a higher percentage of monomer recovery, there is a trade-off between the economic performance (i.e. processes at higher temperatures have a higher energy consumption) and the environmental performance (i.e. credits from processes at higher temperature are higher).

Overall, all these positive outcomes prove the advantages of developing tools to systematically integrate waste-to-resource processes into the life cycle of materials. The adaptation of the well-established methods developed by the PSE community, like superstructure representation and multiobjective optimization, offers a wide range of opportunities to foster circular economy and industrial symbiosis in the search of more sustainable processes and supply chains.

In the particular case of the life cycle of plastics, despite the low technology readiness of processes for its chemical recycling, the recovery of valuable chemicals poses a new appealing change of scope to close material cycles. This rising trend pictures a future with more economically efficient and environmentally friendly life cycle of materials thanks to the methods and tools like the ones developed in this Thesis.

12.2. Future work

This Thesis demonstrates the economic and environmental benefits of systematically PSE methods to assess and optimize the implementation of circular economy concepts into process industries. However, these promising results are only a hint at the improvement potential that could be reached by closing the loop of resources. Therefore, this section suggests some pending research lines identified along this work, some of which have even been tackled to some extent.

- The limitations of the multi-level approach to process and network synthesis should be overcome. Promising results were obtained from the application of synthesis methods at the individual hierarchical

levels, but the integration of both decision-making levels into a single one remains a challenge.

- Further efforts should focus on the efficiency of optimization algorithms. For example, implementing decomposition techniques could solve the appearance of zero-flow singularities in Chapter 11.
- The targeting approach could be extended to consider thermodynamic metrics. Although estimating the thermodynamics of chemical separations is challenging, the incorporation of this targets could significantly reduce the size of the network synthesis problem.
- Chemical recycling processes are promising but still developing at the lab scale. Hence, future work could address the development of a framework for the systematic search of new waste-to-resource processes.
- Concerning the study of plastic waste processing, only chemical recycling alternatives that permit the upcycling of materials are considered. The literature shows other promising waste-to-resource technologies that could be incorporated into the study. For instance, plastic gasification produces fuels, which do not close the cycle of materials but can serve as a more environmentally friendly alternative to fossil fuels. Thus, the methodology proposed could be readily applied in a next future to expand the scope of the study by incorporating and assessing such alternatives.
- Another possible improvement in the line of the pyrolysis of plastics is the consideration of cleaner energy sources to increase its environmental performance. However, a shift to renewable energy sources should be accurately represented to ensure processes maintain its economic and environmental competitiveness.

References

- Aguilar-Oropeza, G., Rubio-Castro, E., Ponce-Ortega, J.M., 2019. Involving Acceptability in the Optimal Synthesis of Water Networks in Eco-Industrial Parks. *Ind. Eng. Chem. Res.* 58, 2268–2279. <https://doi.org/10.1021/acs.iecr.8b04419>
- Ahmed, S., Sahinidis, N. V., 1998. Robust Process Planning under Uncertainty 5885, 1883–1892.
- Al-Fadhli, F.M., Baaqeel, H., El-Halwagi, M.M., 2019. Modular Design of Carbon-Hydrogen-Oxygen Symbiosis Networks over a Time Horizon with Limited Natural Resources. *Chem. Eng. Process. - Process Intensif.* 141, 107535. <https://doi.org/10.1016/j.cep.2019.107535>
- Al-Salem, S.M., Lettieri, P., 2010. Kinetic study of high density polyethylene (HDPE) pyrolysis. *Chem. Eng. Res. Des.* 88, 1599–1606. <https://doi.org/10.1016/j.cherd.2010.03.012>
- Albright, S.C., Winston, W.L., 2012. *Management Science Modeling*, 4th editio. ed. South-Western Cengage Learning.
- Allenby, B., 2006. The ontologies of industrial ecology? *Prog. Ind. Ecol.* 3, 28–40.
- Álvarez, R., Ruiz-Puente, C., 2016. Development of the Tool SymbioSyS to Support the Transition Towards a Circular Economy Based on Industrial Symbiosis Strategies. *Waste and Biomass Valorization* 1–10. <https://doi.org/10.1007/s12649-016-9748-1>
- Amin, A.R., 2001. LDPE/EPDM Multilayer Films Containing Recycled LDPE for Greenhouse Applications. *J. Polym. Environ.* <https://doi.org/10.1023/A:1016040403779>
- Andiappan, V., Tan, R.R., Ng, D.K.S., 2016. An optimization-based negotiation framework for energy systems in an eco-industrial park. *J. Clean. Prod.* 129, 496–507. <https://doi.org/10.1016/j.jclepro.2016.04.023>
- Andrady, A.L., 2011. Microplastics in the marine environment. *Mar. Pollut. Bull.* <https://doi.org/10.1016/J.MARPOLBUL.2011.05.030>
- Andreoni, V., Saveyn, H.G.M., Eder, P., 2015. Polyethylene recycling: Waste

References

- policy scenario analysis for the EU-27. *J. Environ. Manage.* <https://doi.org/10.1016/j.jenvman.2015.04.036>
- Aviso, K.B., 2014. Design of robust water exchange networks for eco-industrial symbiosis. *Process Saf. Environ. Prot.* 92, 160–170. <https://doi.org/10.1016/j.psep.2012.12.001>
- Avraamidou, S., Baratsas, S.G., Tian, Y., Pistikopoulos, E.N., 2020. Circular Economy - A challenge and an opportunity for Process Systems Engineering. *Comput. Chem. Eng.* 133, 106629. <https://doi.org/10.1016/j.compchemeng.2019.106629>
- Aziz, E.A., Hashim, H., 2019. Integrated optimisation of energy-water nexus for industrial site planning. *Chem. Eng. Trans.* 72, 307–312. <https://doi.org/10.3303/CET1972052>
- Baldasano, J.M., Gassó, S., Pérez, C., 2003. Environmental performance review and cost analysis of MSW landfilling by baling-wrapping technology versus conventional system. *Waste Manag.* 23, 795–806. [https://doi.org/10.1016/S0956-053X\(03\)00087-4](https://doi.org/10.1016/S0956-053X(03)00087-4)
- Barcelona Declaration – 10th World Congress of Chemical Engineering, 1–5 October 2017, 2018. *Chem. Eng. Res. Des.* 129, A1–A2. <https://doi.org/10.1016/j.cherd.2017.12.035>
- Beale, E.M.L., 1955. On Minimizing A Convex Function Subject to Linear Inequalities. *J. R. Stat. Soc. Ser. B* 17, 173–184. <https://doi.org/10.2307/2983952>
- Bellman, R.E., 1957. *Dynamic programming*. Princeton University Press, Princeton.
- Benavides, P.T., Sun, P., Han, J., Dunn, J.B., Wang, M., 2017. Life-cycle analysis of fuels from post-use non-recycled plastics. *Fuel* 203, 11–22. <https://doi.org/10.1016/j.fuel.2017.04.070>
- Bhaskar, V., Gupta, S.K., Ray, A.K., 2000. Applications of Multiobjective Optimization in Chemical Engineering, *Reviews in Chemical Engineering*. <https://doi.org/10.1515/revce.2000.16.1.1>
- Biegler, L.T., Grossmann, I.E., 2004. Retrospective on optimization. *Comput. Chem. Eng.* 28, 1169–1192. <https://doi.org/10.1016/j.compchemeng.2003.11.003>
- Bisschop, J., Meeraus, A., 1982. On the development of a general algebraic modeling system in a strategic planning environment. pp. 1–29. <https://doi.org/10.1007/bfb0121223>
- Boix, M., Montastruc, L., Azzaro-Pantel, C., Domenech, S., 2015. Optimization methods applied to the design of eco-industrial parks: A literature review. *J. Clean. Prod.* 87, 303–317.

<https://doi.org/10.1016/j.jclepro.2014.09.032>

- Boix, M., Montastruc, L., Pibouleau, L., Azzaro-Pantel, C., Domenech, S., 2012. Industrial water management by multiobjective optimization: From individual to collective solution through eco-industrial parks. *J. Clean. Prod.* 22, 85–97. <https://doi.org/10.1016/j.jclepro.2011.09.011>
- Bradley, S.P., Hax, A.C., Magnanti, T.L., 1977. *Applied Mathematical Programming*.
- Brandrup, J., Bittner, M., Michaeli, W., Menges, G., 1996. *Recycling and recovery of plastics*. Hanser Publishers.
- Bütün, H., Kantor, I., Maréchal, F., 2019. Incorporating Location Aspects in Process Integration Methodology. *Energies* 12, 3338. <https://doi.org/10.3390/en12173338>
- Cardoso, S.R., Barbosa-Povoa, A.P., Relvas, S., 2016. Integrating financial risk measures into the design and planning of closed-loop supply chains. *Comput. Chem. Eng.* 85, 105–123. <https://doi.org/10.1016/j.compchemeng.2015.10.012>
- Cecelja, F., Trokanas, N., Raafat, T., Yu, M., 2015. Semantic algorithm for Industrial Symbiosis network synthesis. *Comput. Chem. Eng.* 83, 248–266. <https://doi.org/10.1016/j.compchemeng.2015.04.031>
- Chen, Q., Grossmann, I.E., 2017. Recent Developments and Challenges in Optimization-Based Process Synthesis. *Annu. Rev. Chem. Biomol. Eng.* 8, 249–283. <https://doi.org/10.1146/annurev-chembioeng-080615-033546>
- Chertow, M.R., 2000. Industrial Symbiosis: Literature and Taxonomy. *Annu. Rev. Energy Environ.* 25, 313–337. <https://doi.org/10.1146/annurev.energy.25.1.313>
- Dantzig, G.B., 1955. Linear programming under uncertainty. *Manage. Sci.* 1, 197–206.
- Demetrious, A., Crossin, E., 2019. Life cycle assessment of paper and plastic packaging waste in landfill, incineration, and gasification-pyrolysis. *J. Mater. Cycles Waste Manag.* 21, 850–860. <https://doi.org/10.1007/s10163-019-00842-4>
- Donaj, P.J., Kaminsky, W., Buzeto, F., Yang, W., 2012. Pyrolysis of polyolefins for increasing the yield of monomers' recovery. *Waste Manag.* 32, 840–6. <https://doi.org/10.1016/j.wasman.2011.10.009>
- Dong, J., Tang, Y., Nzihou, A., Chi, Y., 2019. Key factors influencing the environmental performance of pyrolysis, gasification and incineration Waste-to-Energy technologies. *Energy Convers. Manag.* 196, 497–512. <https://doi.org/10.1016/j.enconman.2019.06.016>

References

- ECN.TNO, 2019. Phyllis2 - Database for biomass and waste [WWW Document]. URL <https://phyllis.nl/> (accessed 9.20.09).
- Ehrenfeld, J., Gertler, N., 1997. Industrial Ecology in Practice: The Evolution of Interdependence at Kalundborg. *J. Ind. Ecol.* 1, 67–79. <https://doi.org/10.1162/jiec.1997.1.1.67>
- El-Halwagi, M.M., 2006. Process integration, Elsevier, Amsterdam.
- El-Halwagi, M.M., 1997. Pollution Prevention through Process Integration, Pollution Prevention through Process Integration. Elsevier. <https://doi.org/10.1016/b978-0-12-236845-5.x5000-x>
- El-Halwagi, M.M., Spriggs, H.D., 1998. Solve design puzzles with mass integration. *Chem. Eng. Prog.* 94, 25–44.
- Elkington, J., 1997. Cannibals with Forks: the Triple Bottom Line of 21st Century Business. Wiley, Capstone. <https://doi.org/0865713928>
- Ellen MacArthur Foundation, 2015. Towards the Circular Economy: Business rationale for an accelerated transition.
- Ellen MacArthur Foundation, 2014. Towards the Circular Economy: Accelerating the scale-up across global supply chains. <https://doi.org/10.1162/108819806775545321>
- Ellen MacArthur Foundation, 2013a. Towards the Circular Economy: Economic and business rationale for an accelerated transition.
- Ellen MacArthur Foundation, 2013b. Towards the Circular Economy: Opportunities for the consumer goods sector, Ellen MacArthur Foundation. <https://doi.org/10.1162/108819806775545321>
- Eriksson, L., Morandin, M., Harvey, S., 2018. A feasibility study of improved heat recovery and excess heat export at a Swedish chemical complex site. *Int. J. Energy Res.* 42, 1580–1593. <https://doi.org/10.1002/er.3950>
- Erkman, S., 1997. Industrial ecology: An historical view. *J. Clean. Prod.* 5, 1–10. [https://doi.org/10.1016/S0959-6526\(97\)00003-6](https://doi.org/10.1016/S0959-6526(97)00003-6)
- EU Commission, 2014. Towards a circular economy: A zero waste programme for Europe, COM(2014) 398 final. <https://doi.org/10.1017/CBO9781107415324.004>
- European Commission, 2019. The Commission calls for a climate neutral Europe by 2050 [WWW Document]. URL https://ec.europa.eu/clima/news/commission-calls-climate-neutral-europe-2050_en
- European Commission, 2014. Technology readiness levels (TRL) [WWW Document]. URL https://ec.europa.eu/research/participants/data/ref/h2020/wp/2014_201

5/annexes/h2020-wp1415-annex-g-trl_en.pdf

- European Commission - Joint Research Centre, 2010. ILCD Handbook - General guide for Life Cycle Assessment - Detailed guidance, Publications Office. <https://doi.org/10.2788/38479>
- European Parliament, 2019. The European Parliament declares climate emergency [WWW Document]. URL <https://www.europarl.europa.eu/news/en/press-room/20191121IPR67110/the-european-parliament-declares-climate-emergency>
- Eurostat - European Commission, 2019. Recycling – secondary material price indicator [WWW Document].
- Eurostat - European Commission, 2018. Prodcom [WWW Document]. URL <https://ec.europa.eu/eurostat/web/prodcom/>
- Eurostat - European Commission, 2016. Generation of waste by waste category, hazardousness and NACE Rev. 2 activity [WWW Document]. URL https://appsso.eurostat.ec.europa.eu/nui/show.do?dataset=env_wasgen&lang=en (accessed 2.8.19).
- Faraca, G., Martinez-Sanchez, V., Astrup, T.F., 2019. Environmental life cycle cost assessment: Recycling of hard plastic waste collected at Danish recycling centres. *Resour. Conserv. Recycl.* 143, 299–309. <https://doi.org/10.1016/j.resconrec.2019.01.014>
- Foss, B., Lohmann, B., 1998. A field study of the industrial modeling process. *J. Process Control*.
- Fox, J.A., Stacey, N.T., 2019. Process targeting: An energy based comparison of waste plastic processing technologies. *Energy*. <https://doi.org/10.1016/j.energy.2018.12.160>
- Frosch, R.A., Gallopoulos, N.E., 1989. Strategies for Manufacturing. *Sci. Am.* 261, 144–152. <https://doi.org/10.1038/scientificamerican0989-144>
- GAMS Development Corporation, 2020. GAMS User’s Guide.
- Gao, Z., Kaneko, T., Amasaki, I., Nakada, M., 2003. A kinetic study of thermal degradation of polypropylene. *Polym. Degrad. Stab.* 80, 269–274. [https://doi.org/10.1016/S0141-3910\(02\)00407-X](https://doi.org/10.1016/S0141-3910(02)00407-X)
- Gascoin, N., Navarro-Rodriguez, A., Gillard, P., Mangeot, A., 2012. Kinetic modelling of high density polyethylene pyrolysis: Part 1. Comparison of existing models. *Polym. Degrad. Stab.* <https://doi.org/10.1016/j.polymdegradstab.2012.05.008>
- Geissdoerfer, M., Savaget, P., Bocken, N.M.P., Hultink, E.J., 2017. The

References

- Circular Economy – A new sustainability paradigm? *J. Clean. Prod.* 143, 757–768. <https://doi.org/10.1016/j.jclepro.2016.12.048>
- Gerber, L., Fazlollahi, S., Maréchal, F., 2013. A systematic methodology for the environomic design and synthesis of energy systems combining process integration, Life Cycle Assessment and industrial ecology. *Comput. Chem. Eng.* 59, 2–16. <https://doi.org/10.1016/j.compchemeng.2013.05.025>
- Goedkoop, M., Oele, M., Leijting, J., Ponsioen, T., Meijer, E., 2016. Introduction to LCA with SimaPro Title: Introduction to LCA with SimaPro.
- Gonela, V., Zhang, J., 2014. Design of the optimal industrial symbiosis system to improve bioethanol production. *J. Clean. Prod.* 64, 513–534. <https://doi.org/10.1016/j.jclepro.2013.07.059>
- Gonela, V., Zhang, J., Osmani, A., 2015. Stochastic optimization of sustainable industrial symbiosis based hybrid generation bioethanol supply chains. *Comput. Ind. Eng.* 87, 40–65. <https://doi.org/10.1016/j.cie.2015.04.025>
- Gonzalez-Garay, A., Guillen-Gosalbez, G., 2018. SUSCAPE: A framework for the optimal design of SUSTainable ChemicAl ProcEsses incorporating data envelopment analysis. *Chem. Eng. Res. Des.* 137. <https://doi.org/10.1016/j.cherd.2018.07.009>
- Gradus, R.H.J.M., Nillesen, P.H.L., Dijkgraaf, E., van Koppen, R.J., 2017. A Cost-effectiveness Analysis for Incineration or Recycling of Dutch Household Plastic Waste. *Ecol. Econ.* <https://doi.org/10.1016/j.ecolecon.2016.12.021>
- Grossmann, I., 2005. Enterprise-wide optimization: A new frontier in process systems engineering. *AIChE J.* 51, 1846–1857. <https://doi.org/10.1002/aic.10617>
- Grossmann, I.E., 2004. Challenges in the new millennium: Product discovery and design, enterprise and supply chain optimization, global life cycle assessment. *Comput. Chem. Eng.* 29, 29–39. <https://doi.org/10.1016/j.compchemeng.2004.07.016>
- Grossmann, I.E., Ruiz, J.P., 2012. Generalized Disjunctive Programming: A Framework for Formulation and Alternative Algorithms for MINLP Optimization. pp. 93–115. https://doi.org/10.1007/978-1-4614-1927-3_4
- Grosso, M., Motta, A., Rigamonti, L., 2010. Efficiency of energy recovery from waste incineration, in the light of the new Waste Framework Directive. *Waste Manag.* 30, 1238–43. <https://doi.org/10.1016/j.wasman.2010.02.036>
- Guide, D., Wassenhove, L.N. Van, 2009. The Evolution of Closed-Loop

- Supply Chain Research. *Indep. Rev.* 14, 363–375. <https://doi.org/10.1287/opre.1080.0628>
- Guillén-Gosálbez, G., Grossmann, I.E., 2009. Optimal design and planning of sustainable chemical supply chains under uncertainty. *AIChE J.* 55, 99–121. <https://doi.org/10.1002/aic.11662>
- Gutiérrez-Arriaga, C.G., Serna-González, M., Ponce-Ortega, J.M., El-Halwagi, M.M., 2014. Sustainable Integration of Algal Biodiesel Production with Steam Electric Power Plants for Greenhouse Gas Mitigation. *ACS Sustain. Chem. Eng.* 2, 1388–1403. <https://doi.org/10.1021/sc400436a>
- Hart, W.E., Watson, J.P., Woodruff, D.L., 2011. Pyomo: Modeling and solving mathematical programs in Python. *Math. Program. Comput.* 3, 219–260. <https://doi.org/10.1007/s12532-011-0026-8>
- Hiete, M., Ludwig, J., Schultmann, F., 2012. Intercompany Energy Integration: Adaptation of Thermal Pinch Analysis and Allocation of Savings. *J. Ind. Ecol.* 16, 689–698. <https://doi.org/10.1111/j.1530-9290.2012.00462.x>
- Hong, M., Chen, E.Y.X., 2017. Chemically recyclable polymers: A circular economy approach to sustainability. *Green Chem.* <https://doi.org/10.1039/c7gc01496a>
- Honus, S., Kumagai, S., Němček, O., Yoshioka, T., 2016. Replacing conventional fuels in USA, Europe, and UK with plastic pyrolysis gases – Part I: Experiments and graphical interchangeability methods. *Energy Convers. Manag.* 126, 1118–1127. <https://doi.org/10.1016/j.enconman.2016.08.055>
- Hoornweg, D., Bhada-Tata, P., Kennedy, C., 2013. Waste production must peak this century. *Nature*. <https://doi.org/10.1038/502615a>
- Hopwood, B., Mellor, M., O'Brien, G., 2005. Sustainable development: Mapping different approaches. *Sustain. Dev.* 13, 38–52. <https://doi.org/10.1002/sd.244>
- Huang, L., Wang, D., He, C., Pan, M., Zhang, B., Chen, Q., Ren, J., 2019. Industrial wastewater desalination under uncertainty in coal-chemical eco-industrial parks. *Resour. Conserv. Recycl.* 145, 370–378. <https://doi.org/10.1016/j.resconrec.2019.02.036>
- Huijbregts, M.A.J., Steinmann, Z.J.N., Elshout, P.M.F., Stam, G., Verones, F., Vieira, M., Zijp, M., Hollander, A., van Zelm, R., 2017. ReCiPe2016: a harmonised life cycle impact assessment method at midpoint and endpoint level. *Int. J. Life Cycle Assess.* 22, 138–147. <https://doi.org/10.1007/s11367-016-1246-y>

References

- Hwangbo, S., Lee, I.B., Han, J., 2017. Mathematical model to optimize design of integrated utility supply network and future global hydrogen supply network under demand uncertainty. *Appl. Energy* 195, 257–267. <https://doi.org/10.1016/j.apenergy.2017.03.041>
- Hydrogen tools, 2019. Lower and Higher Heating Values of Fuels [WWW Document]. URL <https://h2tools.org/hyarc/calculator-tools/lower-and-higher-heating-values-fuels> (accessed 9.20.09).
- International Organization for Standardization, 2006. ISO 14040:2006: Environmental management – Life cycle assessment – Principles and framework [WWW Document]. URL <https://www.iso.org/standard/37456.html>
- Jackson, T., 2009. *Prosperity without growth: Economics for a Finite Planet*. Earthscan, London.
- Jambeck, J.R., Geyer, R., Wilcox, C., Siegler, T.R., Perryman, M., Andrady, A., Narayan, R., Law, K.L., 2015. Plastic waste inputs from land into the ocean. *Science* (80-.). <https://doi.org/10.1126/science.1260352>
- Jiang, W., Zhang, Z., Deng, C., Tang, X., Feng, X., 2019. Industrial park water system optimization with joint use of water utility sub-system. *Resour. Conserv. Recycl.* 147, 119–127. <https://doi.org/10.1016/j.resconrec.2019.04.005>
- Kalmykova, Y., Sadagopan, M., Rosado, L., 2018. Circular economy – From review of theories and practices to development of implementation tools. *Resour. Conserv. Recycl.* 135, 190–201. <https://doi.org/10.1016/j.resconrec.2017.10.034>
- Kaminsky, W., Predel, M., Sadiki, A., 2004. Feedstock recycling of polymers by pyrolysis in a fluidised bed, in: *Polymer Degradation and Stability*. <https://doi.org/10.1016/j.polyimdegradstab.2003.05.002>
- Kannan, P., Al Shoaibi, A., Srinivasakannan, C., 2014. Temperature effects on the yield of gaseous olefins from waste polyethylene via flash pyrolysis. *Energy and Fuels*. <https://doi.org/10.1021/ef500516n>
- Kim, J., Sen, S.M., Maravelias, C.T., 2013. An optimization-based assessment framework for biomass-to-fuel conversion strategies. *Energy Environ. Sci.* 6, 1093–1104. <https://doi.org/10.1039/c3ee24243a>
- Kim, Y.S., Kim, H.J., Lee, I.B., Yoo, C.K., 2008. Optimization of water-reusing network among the industries in an eco-industrial park complex using water pinch technology. *J. Inst. Control. Robot. Syst.* 14, 1165–1173. <https://doi.org/10.5302/J.ICROS.2008.14.11.1165>
- Kirchherr, J., Reike, D., Hekkert, M., 2017. Conceptualizing the circular economy: An analysis of 114 definitions. *Resour. Conserv. Recycl.* 127,

- 221–232. <https://doi.org/10.1016/j.resconrec.2017.09.005>
- Knudsen, B.R., Kauko, H., Andresen, T., 2019. An Optimal-Control Scheme for Coordinated Surplus-Heat Exchange in Industry Clusters. *Energies* 12, 1877. <https://doi.org/10.3390/en12101877>
- Kolluri, S.S., Esfahani, I.J., Yoo, C.K., 2016. Robust fuzzy and multi-objective optimization approaches to generate alternate solutions for resource conservation of eco-industrial park involving various future events. *Process Saf. Environ. Prot.* 103, 424–441. <https://doi.org/10.1016/j.psep.2016.06.001>
- Kondili, E., Pantelides, C.C., Sargent, R.W.H., 1993. A general algorithm for short-term scheduling of batch operations—I. MILP formulation. *Comput. Chem. Eng.* 17, 211–227. [https://doi.org/10.1016/0098-1354\(93\)80015-F](https://doi.org/10.1016/0098-1354(93)80015-F)
- Korhonen, J., Honkasalo, A., Seppälä, J., 2018. Circular Economy: The Concept and its Limitations. *Ecol. Econ.* 143, 37–46. <https://doi.org/10.1016/j.ecolecon.2017.06.041>
- Krevelen, D.W. van (Dirk W., Nijenhuis, K. te., 2009. Properties of polymers : their correlation with chemical structure ; their numerical estimation and prediction from additive group contributions. Elsevier.
- Lacy, P., Spindler, W., McAndrew, C., 2019. Plastic is a global problem. It's also a global opportunity. *Cologne*.
- Lebreton, L., Slat, B., Ferrari, F., Sainte-Rose, B., Aitken, J., Marthouse, R., Hajbane, S., Cunsolo, S., Schwarz, A., Levivier, A., Noble, K., Debeljak, P., Maral, H., Schoeneich-Argent, R., Brambini, R., Reisser, J., 2018. Evidence that the Great Pacific Garbage Patch is rapidly accumulating plastic. *Sci. Rep.* <https://doi.org/10.1038/s41598-018-22939-w>
- Leong, Y.T., Lee, J.-Y., Tan, R.R., Foo, J.J., Chew, I.M.L., 2017a. Multi-objective optimization for resource network synthesis in eco-industrial parks using an integrated analytic hierarchy process. *J. Clean. Prod.* 143, 1268–1283. <https://doi.org/10.1016/j.jclepro.2016.11.147>
- Leong, Y.T., Lee, J.Y., Tan, R.R., Foo, J.J., Chew, I.M.L., 2017b. Multi-objective optimization for resource network synthesis in eco-industrial parks using an integrated analytic hierarchy process. *J. Clean. Prod.* 143, 1268–1283. <https://doi.org/10.1016/j.jclepro.2016.11.147>
- Lewtas, J., 2007. Air pollution combustion emissions: Characterization of causative agents and mechanisms associated with cancer, reproductive, and cardiovascular effects. *Mutat. Res. - Rev. Mutat. Res.* <https://doi.org/10.1016/j.mrrev.2007.08.003>
- Linnhoff, B., Hindmarsh, E., 1983. The pinch design method for heat

References

- exchanger networks. *Chem. Eng. Sci.* 38, 745–763. [https://doi.org/10.1016/0009-2509\(83\)80185-7](https://doi.org/10.1016/0009-2509(83)80185-7)
- Lovelady, E.M., El-Halwagi, M.M., 2009. Design and integration of eco-industrial parks for managing water resources. *Environ. Prog. Sustain. Energy* 28, 265–272. <https://doi.org/10.1002/ep.10326>
- Luyben, W.L., 2017. Estimating refrigeration costs at cryogenic temperatures. *Comput. Chem. Eng.* <https://doi.org/10.1016/j.compchemeng.2017.03.013>
- Maillé, M., Frayret, J.-M., 2016. Industrial Waste Reuse and By-product Synergy Optimization. *J. Ind. Ecol.* 20, 1284–1294. <https://doi.org/10.1111/jiec.12403>
- Marquardt, W., 1996. Trends in computer-aided process modeling. *Comput. Chem. Eng.* 20, 591–609. [https://doi.org/10.1016/0098-1354\(95\)00195-6](https://doi.org/10.1016/0098-1354(95)00195-6)
- Mastral, F.J., Esperanza, E., García, P., Juste, M., 2002. Pyrolysis of high-density polyethylene in a fluidised bed reactor. Influence of the temperature and residence time. *J. Anal. Appl. Pyrolysis.* [https://doi.org/10.1016/S0165-2370\(01\)00137-1](https://doi.org/10.1016/S0165-2370(01)00137-1)
- Mavrotas, G., 2009. Effective implementation of the ε -constraint method in Multi-Objective Mathematical Programming problems. *Appl. Math. Comput.* 213, 455–465. <https://doi.org/10.1016/j.amc.2009.03.037>
- Meadows, D.H., Randers, J., Meadows, D.L., Meadows, D.H., 2005. Limits to growth : the 30-year update. Routers, London.
- Melrose, J., Perroy, R., Careas, S., 2015. World Population Prospects: The 2015 Revision, Key Findings and Advance Tables. Working Paper No. ESA/P/WP.241. United Nations, Dep. Econ. Soc. Aff. Popul. Div. 1, 1–59. <https://doi.org/10.1017/CBO9781107415324.004>
- Mohamad Shukery, M.F., Hashim, H., Shuin, L.J., 2016. Superstructure-Based Synthesis and Optimization of Oil Palm Eco-Industrial Town: Case Study in Iskandar Malaysia. *Clean Techn Env. Policy* 18, 2119–2129. <https://doi.org/10.3303/CET1545221>
- Montastruc, L., Boix, M., Pibouleau, L., Azzaro-Pantel, C., Domenech, S., 2013. On the flexibility of an eco-industrial park (EIP) for managing industrial water. *J. Clean. Prod.* 43, 1–11. <https://doi.org/10.1016/j.jclepro.2012.12.039>
- Mulvey, J.M., Vanderbei, R.J., Zenions, S.A., 1995. Robust Optimization of Large-Scale Systems. *Oper. Res.* 43, 264–281.
- Muñoz, E., Capón-García, E., Laínez, J.M., España, A., Puigjaner, L., 2013. Considering environmental assessment in an ontological framework for enterprise sustainability. *J. Clean. Prod.* 47, 149–164.

- <https://doi.org/10.1016/j.jclepro.2012.11.032>
- National Academy of Engineering, 2008. NAE Grand Challenges for Engineering [WWW Document]. URL <http://www.engineeringchallenges.org/>
- Ng, R.T.L., Hassim, M.H., Ng, D.K.S., Tan, R.R., El-Halwagi, M.M., 2014. Multi-objective Design of Industrial Symbiosis in Palm Oil Industry. Proc. 8Th Int. Conf. Found. Comput. Process Des. 34, 579–584. <https://doi.org/http://dx.doi.org/10.1016/B978-0-444-63433-7.50081-X>
- Noureldin, M.M.B., El-Halwagi, M.M., 2015. Synthesis of C-H-O Symbiosis Networks. AIChE J. 61, 1242–1262. <https://doi.org/10.1002/aic.14714>
- O'Dwyer, E., Chen, K., Wang, H., Wang, A., Shah, N., Guo, M., 2020. Optimisation of wastewater treatment strategies in eco-industrial parks: Technology, location and transport. Chem. Eng. J. 381, 122643. <https://doi.org/10.1016/j.cej.2019.122643>
- Onwudili, J.A., Insura, N., Williams, P.T., 2009. Composition of products from the pyrolysis of polyethylene and polystyrene in a closed batch reactor: Effects of temperature and residence time. J. Anal. Appl. Pyrolysis. <https://doi.org/10.1016/j.jaap.2009.07.008>
- Onwudili, J.A., Muhammad, C., Williams, P.T., 2018. Influence of catalyst bed temperature and properties of zeolite catalysts on pyrolysis-catalysis of a simulated mixed plastics sample for the production of upgraded fuels and chemicals. J. Energy Inst. <https://doi.org/10.1016/j.joei.2018.10.001>
- Pan, M., Sikorski, J., Akroyd, J., Mosbach, S., Lau, R., Kraft, M., 2016. Design technologies for eco-industrial parks: From unit operations to processes, plants and industrial networks. Appl. Energy 175, 305–323. <https://doi.org/10.1016/j.apenergy.2016.05.019>
- Panu, M., Topolski, K., Abrash, S., El-Halwagi, M.M., 2019. CO₂ footprint reduction via the optimal design of Carbon-Hydrogen-Oxygen SYmbiosis Networks (CHOSYNs). Chem. Eng. Sci. 203, 1–11. <https://doi.org/10.1016/j.ces.2019.03.066>
- Papoulias, S.A., Grossmann, I.E., 1983. A structural optimization approach in process synthesis-I. Utility systems. Comput. Chem. Eng. 7, 695–706. [https://doi.org/10.1016/0098-1354\(83\)85022-4](https://doi.org/10.1016/0098-1354(83)85022-4)
- Park, K.B., Jeong, Y.S., Guzelciftci, B., Kim, J.S., 2019. Characteristics of a new type continuous two-stage pyrolysis of waste polyethylene. Energy. <https://doi.org/10.1016/j.energy.2018.10.078>
- Phyllis2 database for biomass and waste, 2019. Phyllis2, database for biomass and waste.

References

- Pistikopoulos, E.N., 1995. Uncertainty in process design and operations. *Comput. Chem. Eng.* 19, 553–563. [https://doi.org/10.1016/0098-1354\(95\)87094-6](https://doi.org/10.1016/0098-1354(95)87094-6)
- PlasticsEurope, 2018. PlasticsEurope. Plastics – the facts 2018. Brussels.
- Platzer, N., 1983. Branched polyethylene. LDPE and LLDPE. *Ind. Eng. Chem. Prod. Res. Dev.* 22, 158–160. <https://doi.org/10.1021/i300009a035>
- Prékopa, A., 1995. Stochastic Programming. Kluwer Academic Publishers.
- Prieto-Sandoval, V., Jaca, C., Ormazabal, M., 2018. Towards a consensus on the circular economy. *J. Clean. Prod.* 179, 605–615. <https://doi.org/10.1016/j.jclepro.2017.12.224>
- Raafat, T., Trokanas, N., Cecelja, F., Bimi, X., 2013. An ontological approach towards enabling processing technologies participation in industrial symbiosis. *Comput. Chem. Eng.* 59, 33–46. <https://doi.org/10.1016/j.compchemeng.2013.03.022>
- Ragaert, K., Delva, L., Van Geem, K., 2017. Mechanical and chemical recycling of solid plastic waste. *Waste Manag.* <https://doi.org/10.1016/j.wasman.2017.07.044>
- Raman, R., Grossmann, I.E., 1994. Modelling and computational techniques for logic based integer programming. *Comput. Chem. Eng.* 18, 563–578. [https://doi.org/10.1016/0098-1354\(93\)E0010-7](https://doi.org/10.1016/0098-1354(93)E0010-7)
- Ramos, M.A., Boix, M., Aussel, D., Montastruc, L., Domenech, S., 2016. Water integration in eco-industrial parks using a multi-leader-follower approach. *Comput. Chem. Eng.* 87, 190–207. <https://doi.org/10.1016/j.compchemeng.2016.01.005>
- Rangaiah, G.P., 2009. Multi-objective optimization: techniques and applications in chemical engineering.
- Ren, J., Liang, H., Dong, L., Sun, L., Gao, Z., 2016. Design for sustainability of industrial symbiosis based on energy and multi-objective particle swarm optimization. *Sci. Total Environ.* 562. <https://doi.org/10.1016/j.scitotenv.2016.04.092>
- Ripple, W.J., Wolf, C., Newsome, T.M., Barnard, P., Moomaw, W.R., 2019. World Scientists’ Warning of a Climate Emergency. *Bioscience*. <https://doi.org/10.1093/biosci/biz088>
- Rosa, P., Sassanelli, C., Terzi, S., 2019. Towards Circular Business Models: A systematic literature review on classification frameworks and archetypes. *J. Clean. Prod.* <https://doi.org/10.1016/j.jclepro.2019.117696>
- Rubio-Castro, E., Ponce-Ortega, J.M., El-Halwagi, M.M., Serna-González, M., Jiménez-Gutiérrez, A., 2011. Synthesis of water integration networks in

- ecoindustrial parks. *Comput. Aided Chem. Eng.* 29, 1170–1174. <https://doi.org/10.1016/B978-0-444-54298-4.50013-1>
- Sahinidis, N. V., 2004. Optimization under uncertainty: State-of-the-art and opportunities. *Comput. Chem. Eng.* 28, 971–983. <https://doi.org/10.1016/j.compchemeng.2003.09.017>
- Salema, M.I.G., Barbosa-Povoa, A.P., Novais, A.Q., 2010. Simultaneous design and planning of supply chains with reverse flows: A generic modelling framework. *Eur. J. Oper. Res.* 203, 336–349. <https://doi.org/10.1016/j.ejor.2009.08.002>
- Sauvé, S., Bernard, S., Sloan, P., 2016. Environmental sciences, sustainable development and circular economy: Alternative concepts for trans-disciplinary research. *Environ. Dev.* 17, 48–56. <https://doi.org/10.1016/j.envdev.2015.09.002>
- Seider, W.D., Lewin, D.R., Seader, J.D., Widagdo, S. (Chemical engineer), Gani, R. (Rafiqul), Ng, K.M., n.d. *Product and process design principles : synthesis, analysis, and evaluation.*
- Sinnott, R.K., Towler, G., 2013. *Chemical Engineering Design, Chemical Engineering Design.* <https://doi.org/10.1016/C2009-0-61216-2>
- Smith, E.M., 1996. *On the optimal design of continuous processes*, Ph.D. Dissertation, under supervision of C. Pantelides. Imperial College of Science, Technology and Medicine, London, UK.
- Souza, G.C., 2013. Closed-Loop Supply Chains: A Critical Review, and Future Research*. *Decis. Sci.* 44, 7–38. <https://doi.org/10.1111/j.1540-5915.2012.00394.x>
- Spallina, V., Velarde, I.C., Jimenez, J.A.M., Godini, H.R., Gallucci, F., Van Sint Annaland, M., 2017. Techno-economic assessment of different routes for olefins production through the oxidative coupling of methane (OCM): Advances in benchmark technologies. *Energy Convers. Manag.* <https://doi.org/10.1016/j.enconman.2017.10.061>
- Stahel, W.R., 2016. The Circular Economy. *Nature* 531, 435–438.
- Stahel, W.R., Reday, G., 1976. *The Potential for Substituting Manpower for Energy.* Report to the Commission of the European Communities.
- Stankiewicz, A.I., Moulijn, J.A., 2000. Process intensification: Transforming chemical engineering. *Chem. Eng. Prog.* 96, 22–33. <https://doi.org/10.1002/btpr.305>
- Studer, R., Benjamins, V.R., Fensel, D., 1998. Knowledge Engineering: Principles and methods. *Data Knowl. Eng.* 25, 161–197. [https://doi.org/10.1016/S0169-023X\(97\)00056-6](https://doi.org/10.1016/S0169-023X(97)00056-6)

References

- Tan, R.R., Andiappan, V., Kin Wan, Y., Ng, R.T.L., Ng, D.K.S., 2016a. An optimization-based cooperative game approach for systematic allocation of costs and benefits in interplant process integration. *Chem. Eng. Res. Des.* 106, 43–58. <https://doi.org/http://dx.doi.org/10.1016/j.cherd.2015.11.009>
- Tan, R.R., Andiappan, V., Wan, Y.K., Ng, R.T.L., Ng, D.K.S., 2016b. An optimization-based cooperative game approach for systematic allocation of costs and benefits in interplant process integration. *Chem. Eng. Res. Des.* 106, 43–58. <https://doi.org/10.1016/j.cherd.2015.11.009>
- Tanaka, H., Asai, K., 1984. Fuzzy linear programming problems with fuzzy numbers. *Fuzzy Sets Syst.* 13, 1–10.
- The Standing Committee of the National People's Congress China, 2008. Circular Economy Promotion Law of the People's Republic of China.
- The World Bank, 2019. Inflation, GDP deflator (annual %). [WWW Document]. [URL https://data.worldbank.org/indicator/NY.GDP.DEFL.KD.ZG?start=1998](https://data.worldbank.org/indicator/NY.GDP.DEFL.KD.ZG?start=1998) (accessed 9.20.02).
- Tiu, B.T.C., Cruz, D.E., 2017. An MILP model for optimizing water exchanges in eco-industrial parks considering water quality. *Resour. Conserv. Recycl.* 119, 89–96. <https://doi.org/10.1016/j.resconrec.2016.06.005>
- Topolski, K., Noureldin, M.M.B., Eljack, F.T., El-Halwagi, M.M., 2018. An anchor-tenant approach to the synthesis of carbon-hydrogen-oxygen symbiosis networks. *Comput. Chem. Eng.* 116, 80–90. <https://doi.org/10.1016/j.compchemeng.2018.02.024>
- United Nations, 2016. Sustainable Development Goals.
- Vargas Santillán, A., Farias Sanchez, J.C., Pineda Pimentel, M.G., Castro Montoya, A.J., 2016. Olefins and Ethanol from Polyolefins: Analysis of Potential Chemical Recycling of Poly(ethylene) Mexican Case. *Int. J. Chem. React. Eng.* <https://doi.org/10.1515/ijcre-2015-0217>
- Wernet, G., Bauer, C., Steubing, B., Reinhard, J., Moreno-Ruiz, E., Weidema, B., 2016. The ecoinvent database version 3 (part I): overview and methodology. *Int. J. Life Cycle Assess.* <https://doi.org/10.1007/s11367-016-1087-8>
- Westerhout, R.W.J., Waanders, J., Kuipers, J.A.M., van Swaaij, W.P.M., 1997. Kinetics of the Low-Temperature Pyrolysis of Polyethylene, Polypropene, and Polystyrene Modeling, Experimental Determination, and Comparison with Literature Models and Data. *Ind. Eng. Chem. Res.* 36, 1955–1964. <https://doi.org/10.1021/ie960501m>
- Williams, P.T., Williams, E.A., 1999. Interaction of plastics in mixed-plastics

- pyrolysis. *Energy and Fuels* 13, 188–196.
<https://doi.org/10.1021/ef980163x>
- Winans, K., Kendall, A., Deng, H., 2017. The history and current applications of the circular economy concept. *Renew. Sustain. Energy Rev.* 68, 825–833. <https://doi.org/10.1016/j.rser.2016.09.123>
- World Commission on Environment and Development, Brundtland, G.H., Khalid, M., 1987. *Our common future*.
- World Economic Forum; Ellen MacArthur Foundation; McKinsey & Company, 2016. *The New Plastics Economy – Rethinking the future of plastics* [WWW Document]. URL <http://www.ellenmacarthurfoundation.org/publications>
- Xu, Y., Wang, Z., Jiang, Y., Yang, Y., Wang, F., 2019. Small-world network analysis on fault propagation characteristics of water networks in eco-industrial parks. *Resour. Conserv. Recycl.* 149, 343–351. <https://doi.org/10.1016/j.resconrec.2019.05.040>
- Yee, T.F., Grossmann, I.E., Kravanja, Z., 1990. Simultaneous optimization models for heat integration-I. Area and energy targeting and modeling of multi-stream exchangers. *Comput. Chem. Eng.* 14, 1151–1164. [https://doi.org/10.1016/0098-1354\(90\)85009-Y](https://doi.org/10.1016/0098-1354(90)85009-Y)
- Yeomans, H., Grossmann, I.E., 1999. A systematic modeling framework of superstructure optimization in process synthesis. *Comput. Chem. Eng.* 23, 709–731. [https://doi.org/10.1016/S0098-1354\(99\)00003-4](https://doi.org/10.1016/S0098-1354(99)00003-4)
- Yoo, C.K., Lee, T.Y., Kim, J., Moon, I.I., Jung, J.H., Han, C., Oh, J.-M., Lee, I.-B., 2007. Integrated water resource management through water reuse network design for clean production technology: State of the art. *Korean J. ...* 24, 567–576. <https://doi.org/10.1007/s11814-007-0004-z>
- Yoshimura, Y., Kijima, N., Hayakawa, T., Murata, K., Suzuki, K., Mizukami, F., Matano, K., Konishi, T., Oikawa, T., Saito, M., Shiojima, T., Shiozawa, K., Wakui, K., Sawada, G., Sato, K., Matsuo, S., Yamaoka, N., 2001. Catalytic cracking of naphtha to light olefins. *Catal. Surv. from Japan*. <https://doi.org/10.1023/A:1011463606189>
- Zeaiter, J., 2014. A process study on the pyrolysis of waste polyethylene. *Fuel*. <https://doi.org/10.1016/j.fuel.2014.05.028>
- Zeballos, L.J., Méndez, C.A., Barbosa-Povoa, A.P., 2016. Design and Planning of Closed-Loop Supply Chains: A Risk-Averse Multistage Stochastic Approach. *Ind. Eng. Chem. Res.* 55, 6236–6249. <https://doi.org/10.1021/acs.iecr.5b03647>
- Zhang, C., Romagnoli, A., Zhou, L., Kraft, M., 2017a. Knowledge management of eco-industrial park for efficient energy utilization

References

- through ontology-based approach. *Appl. Energy* 204, 1412–1421.
<https://doi.org/10.1016/j.apenergy.2017.03.130>
- Zhang, C., Romagnoli, A., Zhou, L., Kraft, M., 2017b. Knowledge management of eco-industrial park for efficient energy utilization through ontology-based approach. *Appl. Energy*.
<https://doi.org/10.1016/j.apenergy.2017.03.130>
- Zhou, L., Zhang, C., Karimi, I.A., Kraft, M., 2018. An ontology framework towards decentralized information management for eco-industrial parks. *Comput. Chem. Eng.* 118, 49–63.
<https://doi.org/10.1016/j.compchemeng.2018.07.010>
- Zimmermann, H.-J., 1991. *Fuzzy Set Theory and Its Application*, 2nd ed. Kluwer Academic Publishers., Boston.
- Zimmermann, H.J., 1978. Fuzzy programming and linear programming with several objective functions. *Fuzzy Sets Syst.* 1, 45–55.
[https://doi.org/10.1016/0165-0114\(78\)90031-3](https://doi.org/10.1016/0165-0114(78)90031-3)
- Zitzler, E., Thiele, L., Laumanns, M., Fonseca, C.M., da Fonseca, V.G., 2003. Performance assesment of multiobjective optimizers: an analysis and review. *Evol. Comput.* 7, 117–132.
<https://doi.org/10.1109/TEVC.2003.810758>